



**North Eastern Regional Agricultural Marketing Corporation Ltd.**  
(A Government of India Enterprise)

NERAMAC Complex, Panjabari Road, Near Six Mile Flyover  
Six Mile, Guwahati, Assam-781022  
Website: [www.neramac.com](http://www.neramac.com)

**Bidding Document**

For

Execution of the Work “Construction of Agarwood Oil & Chips  
Processing Centre at Golaghat (Assam) & Kadamtala (Tripura)  
on EPC mode of Contract”

**Notice Inviting Tender (NIT)**

Sl. No.	Particulars	Details
01	Tender No.	<b>NER/Agribusiness/Agar-CD/584</b>
02	Name of Work	Execution of Work “Construction of Agarwood Processing Units at Golaghat, Assam, & Kadamtala, Tripura on EPC mode of Contract.
03	Earnest Money Deposit (EMD) (Refundable)  Exempted for NSIC/MSME/SSI	<p>The bidder shall submit an Earnest Money Deposit (EMD) of <b>Rs. 14,00,000.00/-</b> (for both locations) online through the portal, in favour of North Eastern Regional Agricultural Marketing Corporation Ltd. (NERAMAC). The EMD shall be enclosed/uploaded along with the Technical Bid. The EMD of the successful bidder shall be retained as part of the Performance Security, while EMDs of unsuccessful bidders shall be returned without interest after finalization of the tender. Tenders received without EMD shall be rejected.</p> <p><b>Bank Details for deposition of EMD:</b> Name: North Eastern Regional Agricultural Marketing Corporation Ltd. Name of Bank: Union Bank of India Branch Name: GS Road Account No.: 555801010050164 IFSC: UBIN0555584</p> <p>(OR)</p> <p>Copy of NSIC/MSME/SSI Registration. (if available) shall be submitted for exemption.</p>
04	Tender Document Fee (Non–Refundable)	<p><b>Rs 5,000/-</b></p> <p><b>Bank Details for deposition of Tender Fee:</b> Name: North Eastern Regional Agricultural Marketing Corporation Ltd. Name of Bank: Union Bank of India Branch Name: GS Road Account No.: 555801010050164 IFSC: UBIN0555584</p>

05	Validity of Tender	90 days from the date of opening of Financial Bid
06	Type of Tender	Work Contract (CivilWorks)
07	Period of Work	<b>9 Months</b> from the date of handing over of site to the contractor
08	Defects Liability Period (DLP)	<b>12 Months</b> from the date of actual completion of Work and handing over to NERAMAC
09	Mode of Submission of Tender	<b>Online Mode</b> through NERAMAC e-Procurement Portal. <a href="https://neramac.ewizard.in/">https://neramac.ewizard.in/</a>
10	Date of Pre-Bid Meeting	<b>6<sup>th</sup> May 2026 at 1500 Hrs</b>
11	Last Date of Submission of Bid	<b>21<sup>st</sup> May 2026 at 2359 Hrs</b>
12	Technical Bid Opening	<b>22<sup>nd</sup> May 2026 at 1100 Hrs</b>
13	Financial Bid Opening	<b>25<sup>th</sup> May 2026 at 1100 Hrs</b>

### 1. Eligibility Criteria:

- I. The eligibility criteria prescribed under this tender are designed to ensure that only **competent, experienced, and financially sound construction agencies** participate in the execution of the Agarwood Processing Plant (CPC) on EPC basis. These criteria serve as a preliminary screening mechanism to assess the bidder's **legal standing, financial capability, technical experience, resource availability, and compliance with statutory requirements**, thereby minimizing execution risks and ensuring successful project delivery.
- II. The interested agency shall have either Head Office or Branch Office in North East. Affidavit in stamp paper with a value of **Rs. 100/-** (Rupees One Hundred) only with address of Head Office/ Branch Office in North East along with copy of latest electricity bill shall be enclosed. Non-fulfilment of all the above said criteria shall result in rejection of Bids. Any rejected offer shall not be eligible for execution of project as defined in this tender. No change in bid conditions (other than grammar mistakes) shall be made nor will such requests be entertained.
- III. Bidder must have valid registration numbers for PAN, GST, and applicable labor laws (e.g. EPF, ESI, Labour License, LIN). All such registrations must be valid as on the date of bid submission. Proofs of GST registration, ESI and EPF registration, etc., are to be furnished with the technical bid. The bidder should be GST-compliant and regularly file GST returns.
- IV. The **financial capacity criteria** are intended to evaluate the bidder's ability to undertake and sustain the execution of construction works without financial constraints. The requirement of a **minimum average annual turnover of ₹30 Crore over the last three financial years** demonstrates that the bidder has sufficient business volume and operational scale. Similarly, the **minimum net worth requirement of ₹5 Crore** ensures financial stability and the ability to absorb

project-related risks. The submission of a **Bank Solvency Certificate of ₹10 Crore** further establishes the bidder's creditworthiness and access to financial resources, which is critical for smooth project execution, especially under an EPC contract where upfront investment and cash flow management are essential.

- V. The **technical experience criteria** ensure that the bidder has prior hands-on experience in executing similar execution of works especially in Food Processing Plants under EPC mode of contract. By mandating completion of **at least three projects of minimum value ₹2 Crore each within the last seven years**, the tender ensures that only those firms with proven execution capability, familiarity with project challenges, and experience in handling infrastructure works are considered. Experience with Government departments or Public Sector Undertakings further strengthens credibility, as such projects typically involve adherence to strict quality, safety, and compliance standards. In addition, bidders must have **prior experience of executing at least one project in the North Eastern Region, preferably in the states of Assam and/or Tripura**, which demonstrates familiarity with the region's unique geographical conditions, high rainfall patterns, logistical constraints, and regulatory environment. This requirement is critical to ensure smooth execution in the project locations and to reduce risks associated with terrain, climate, and accessibility.
- VI. The requirement related to **equipment and machinery availability** is included to verify that the bidder possesses the necessary construction resources for timely and efficient execution. Ownership or assured access to key equipment such as tippers, excavators, and concrete mixers indicates that the contractor is operationally equipped and not solely dependent on external hiring, thereby reducing the risk of delays.
- VII. Further, the requirement for **statutory compliance and non-blacklisting declaration** ensures that only ethically compliant and legally sound firms participate in the tender. This protects the Authority from engaging agencies with poor performance history, legal disputes, or regulatory violations.
- VIII. The inclusion of **minimum technical manpower requirements**, such as availability of qualified Civil and MEP engineers along with supervisory staff, ensures that the bidder has the necessary human resources to manage and execute the project professionally, maintaining quality and adherence to timelines.
- IX. Finally, the bidder's declaration confirming understanding of the **EPC nature of the contract with project cost ceiling of ₹3.50 Crore per location each with 2605 Sqm (28040 Sqft) of plot area** ensures that the bidder acknowledges the scope, risks, and financial constraints upfront. This is particularly important to prevent post-award disputes related to cost escalation or scope misinterpretation.
- X. Litigation History-Bidders must disclose any past or ongoing litigation/arbitration cases for the last 3 years. A self-declaration with details of disputes (if any) must be provided. Bidders with a history of contract default or adverse arbitration awards may be disqualified.
- XI. Bid Security (EMD) Bidders shall furnish the EMD as specified in the NIT table. EMD must remain valid for at least 45 days beyond the final bid validity period.
- XII. Refund and Forfeiture of EMD EMDs of unsuccessful bidders will be returned within 15 days of finalization of award. The EMD of the successful bidder will be held as part of the security deposit and returned only after receipt of the Performance

Guarantee. If the bidder withdraws or modifies the bid during its validity, or if the successful bidder fails to sign the contract or furnish Performance Guarantee within the stipulated time, the EMD will be forfeited.

- i. **Bid Submission:** Bidders must submit their bids online at the specified e-Procurement portal by the deadline. The Technical Bid and Financial Bid should be uploaded as separate files. Hard copy submissions are not required (unless specifically requested for certain documents). All pages of the bid (especially scanned copies of forms and documents) should be signed and stamped by the authorized signatory of the bidder. Incomplete or unsigned bids are liable to rejection. No bids will be accepted after the 3 last date/time of submission. It is the bidder's responsibility to ensure that the bid is submitted successfully in the e-portal before the deadline.
- ii. **Bid Opening & Evaluation:** Technical Bids will be opened first at the specified date/time. Bidders' representatives may attend the opening online. The Technical Bids shall be evaluated for compliance with eligibility and technical criteria. During evaluation, NERAMAC may seek clarifications or additional documents, which the bidders must respond to promptly. Bidders meeting the requirements will be declared Technically Qualified. The Financial Bids of only technically qualified bidders will then be opened at a later date (informed separately). The contract will be awarded to the lowest priced (L1) bidder among the qualified bids, subject to reasonableness of rates and compliance with all terms. Method of evaluation and detailed criteria for determining the L1 bidder are described in the tender document and will be strictly followed.
- iii. **NERAMAC's Rights:** NERAMAC reserves the right to accept or reject any or all bids, wholly or partly, without assigning any reason whatsoever. NERAMAC also reserves the right to annul the tender process at any stage or to withdraw the work, in full or in part, without incurring any liability. The decision of the NERAMAC shall be final and binding in this regard.
- iv. After award, if the selected contractor's performance is found unsatisfactory or if the contractor breaches any terms, NERAMAC reserves the right to terminate the contract (in whole or part) with due notice, and get the remaining work completed at the contractor's risk and cost. In such event, appropriate penalties will be applied and the contractor's security may be forfeited to cover the extra cost. Further, NERAMAC may debar such contractor from future tenders if their performance is found to be deficient.

### XIII. Stage-I: Eligibility Screening (Mandatory Qualification)

#### Bid Evaluation Sheet – Stage I

Sl. No.	Criteria	Requirement	Documents Required	Status (Pass/Fail)
1	Legal Status	Registered Company / Firm / LLP	Incorporation Certificate, PAN, GST	
2	Turnover	Avg. ₹30 Cr (last 3 FY)	CA Certificate, Audited Balance Sheet	
3	Net Worth	≥ ₹5 Cr	CA Certificate	
4	Bank	≥ ₹10 Cr	Solvency Certificate (<6	

	Solvency		months)	
5	Experience	3 projects $\geq$ ₹2 Cr each	Work Orders + Completion Certificates	
6	Regional Experience	$\geq$ 1 project in NE (Assam/Tripura preferred)	Work Order + Completion Certificate	
7	Equipment	Required machinery available	RC / Invoice copies in the name of Registered Company	
8	Non-Blacklisting	Required	Self Declaration	
9	Technical Staff	(i) Civil Engineer (ii) MEP Engineer (iii) QA/QC Personnel	CV / Qualification proof	

### General Conditions

- All experts must be **on payroll or contractually engaged** with the bidder/consultant.
- The **same individual shall not be proposed for multiple positions**.
- Detailed CVs of all experts must be submitted in prescribed format.
- Experience must be supported with documentary evidence (project credentials/work orders)

### Stage-II: Financial Evaluation (L1 Selection)

- Only technically qualified bidders will be considered.
- Lowest quoted bidder (**L1**) will be selected.

# **Section I: Instruction to Bidders**

## **1. General Instructions**

### **1.1. Scope of Bid**

The NERAMAC (referred to as the “Employer”) issues this tender for the works described in Section II: Scope of Work. The successful bidder (the “Contractor”) will be expected to complete the works within the stipulated time and in accordance with the terms and conditions of the contract.

### **1.2. Bidder’s Responsibility**

The bidder is expected to examine all instructions, forms, terms, specifications, and project requirements in the tender documents. It is essential that the bidder fully inform themselves of site conditions and work requirements before submitting a bid.

### **1.3. Site Visit**

Bidders are advised to visit the project site in Golaghat, Assam, and Kadamtala, Tripura, and acquaint themselves with terrain, accessibility, local conditions, climate, labor availability, and any other relevant aspects. Any lack of information will not relieve the bidder of responsibility for estimating the cost or time effectively. Claims arising from ignorance of site conditions will not be entertained.

### **1.4. Amendment of Tender**

NERAMAC may issue addenda/corrigenda to the tender documents. Any such amendments will be hosted on the same portal only. Bidders should regularly check the portal for updates and acknowledge all addenda in their bid. NERAMAC will not individually intimate bidders about the issuance of corrigenda. Failure to account for such amendments in the bid will not be a valid ground for waiver of any requirements.

### **1.5. Two-Part Bid**

The bid shall be submitted in two parts – **Technical Bid** and **Financial Bid** – as detailed below. No price information should be included in the Technical Bid. Any financial disclosure in the Technical Bid may lead to disqualification.

## **2. Technical Bid (Part-I)**

The Technical Bid shall contain all information and documents to allow NERAMAC to assess the bidder’s qualifications, experience, and capability without reference to price. The Technical Bid should be submitted in the formats provided in Section VII (Forms & Annexures). Key contents to include:

- i. Bid Submission Form: A signed and stamped Bid Submission/Acceptance Letter (as per Form I) on the bidder’s letterhead, expressing acceptance of tender terms.
- ii. Bid Security (EMD): Proof of EMD submission (scanned DD/NEFT) or valid exemption certificate (for NSIC/MSME) should be uploaded.
- iii. Eligibility Documents: Documents supporting all criteria listed in the NIT:

- Work Completion Certificates for similar projects, indicating project name, value, completion date, and client details. These certificates must be issued by an officer not below rank of Executive Engineer or equivalent from the client organization. The performance of completed works should be satisfactory (certificate to indicate “Good” or above).
  - Financial statements (audited balance sheets and profit/loss) for the last 3 years; CA certificate if required, and Annexure III (financial info format) duly filled.
  - Solvency Certificate (Form XII) from bank.
  - Copy of GST registration, PAN card, EPF & ESI registration, labor license (if already available) etc.
  - Declaration of litigation history (if any) and a declaration of not being blacklisted.
- iv. **Technical Proposal:** A brief note or method statement on how the bidder intends to execute the work, including manpower planning, equipment to be deployed, and a work schedule or milestones for NERAMAC.
  - v. **Power of Attorney:** If the bid is signed by an authorized person (other than the owner/MD of the firm), a valid Power of Attorney authorizing the signatory should be enclosed.
  - vi. All documents must be numbered, indexed, and duly signed by the bidder’s authorized representative. Every page of the bid and its enclosures should be signed and sealed for authenticity. Any interlineation, erasures or corrections in the bid should be initialed by the person signing the bid, with date.
  - vii. **Submission:** The Technical Bid (all documents) should be compiled in a single PDF or in the designated fields on the e-portal. No financial information should be included in this part.
  - viii. **Confidentiality:** All information submitted by bidders will be treated as confidential and will not be divulged to any outside agency, except for lawful requirement or with the bidder’s permission.

### 3. Financial Bid (Part-II)

The Financial Bid shall be filled in the prescribed format provided with this document (typically an Excel or online form on the portal). The bidder must quote the rates inclusive of GST. Any required field should not be kept blank.

The rates should be quoted in both figures and words wherever required. In case of any discrepancy between the figure and word, the lower of the two shall be considered for evaluation. The bidders are cautioned to fill the rates carefully and cross-check totals. If there is an arithmetic error in the total amount, NERAMAC will correct the total by summing the individual rates.

The Financial Bid must be digitally signed and submitted in the allocated section of the e-tender. It should not be merged with the technical documents.

**NOTE: The list of BoQ items supplied with this document is based on preliminary conceptual drawings only. The list is subject to addition and deletion of items after**

**preparation of detail drawings and final working estimate to be submitted and presented by the bidder, keeping the cost ceiling of Rs 3.50 Crore for each location.**

**4. Bid Validity and Withdrawal-**

Bids shall remain valid for 90 (ninety) days from the date of opening of the Financial Bids. A bid with a shorter validity period is liable to be rejected as non-responsive. In exceptional circumstances, prior to expiry of the original bid validity, NERAMAC may request the bidders to extend the period of validity for a specified additional period. The request and the responses shall be made in writing. A bidder may refuse the request without forfeiting the EMD. However, a bidder agreeing to the request will not be permitted to modify their bid, and will be required to extend the validity of the EMD accordingly.

Withdrawal or modification of bids is not allowed during the bid validity period. If any bidder, without written consent of NERAMAC, attempts to withdraw their bid before the end of validity, NERAMAC will forfeit the EMD of that bidder.

**5. Bid Opening and Evaluation Procedure**

**5.1. Technical Bid Opening**

The Technical bids will be opened on the specified date/time by the Tender Opening Committee. The names of bidders and the presence of requisite EMD/Tender fee will be announced. The technical bids will then be evaluated for completeness and adherence to eligibility and technical criteria.

**5.2. Detailed Evaluation**

The evaluation committee will scrutinize the technical bids to determine whether they are substantially responsive to the requirements. The committee may seek clarifications on documents; such requests will be communicated through the portal/email and the bidder should respond in a timely manner. If a bidder does not provide clarifications or required documents within the specified time, their bid may be evaluated on the available information or rejected if the deficiency is critical.

**5.3. Determination of Responsiveness**

A technically responsive bid is one that conforms to all terms, conditions, and specifications of the tender without material deviation. A material deviation is one that affects in any substantial way the scope, quality, or performance of the work or which limits in any substantial way the Employer's rights or the bidder's obligations. NERAMAC reserves the right to reject any bid that is technically unsatisfactory or deemed non-responsive.

**5.4. Technical Qualification & Presentation**

Bidders who meet the eligibility and technical criteria may be invited to make a presentation of their work plan, past experience, detailed drawings and final working

estimate. This is to help assess the bidder's understanding and approach. The presentation, if conducted, will be prior to opening of financial bids.

### **5.5. Financial Bid Opening**

The financial bids of only those bidders who are found technically qualified will be opened on a later date as notified. The opening will be done in presence of authorized representatives of qualified bidders (if they choose to attend) or opened online with due protocol. The total quoted price (inclusive of taxes) of each bidder will be read out and recorded.

### **5.6. Evaluation and Award**

The contract will be awarded to the Lowest evaluated bidder (L1). The Lowest bidder will be decided on the basis of the quoted price in the price bid form. If there is a tie in lowest price, the bidder with superior technical credentials (e.g. higher value of similar work experience or better average turnover) may be given preference, or as per GoI procurement norms. NERAMAC will determine if the L1 price is reasonable and within available budget. If the L1 bid is found abnormally low, the bidder may be asked for clarification/analysis and to give additional Performance Security as per Govt. norms or the bid may be rejected if the bidder cannot demonstrate ability to perform at that price.

NERAMAC reserves the right to negotiate with the L1 bidder if required, or to accept the tender in part if so mentioned in tender. However, for this single-package works tender, normally the whole work will be awarded to one bidder on L1 basis.

After evaluation, NERAMAC will issue a Letter of Acceptance (LoA) to the successful bidder. The bidder must accept the LoA and fulfill all requirements (such as submission of Performance Guarantee and signing of contract) within the stipulated time (generally 15 days). Failure to do so may result in cancellation of award and forfeiture of EMD, in which case NERAMAC may award the work to the next eligible bidder or take other appropriate action.

## **6. Other Instructions and Important Conditions**

### **6.1. Language & Units**

The bid and all supporting documents shall be in English. All price figures shall be in Indian Rupees (INR) only. Dimensions and technical parameters shall be in metric units (SI).

## **6.2. Authorship and Authenticity**

Every document submitted must be duly self-attested or notarized as required. Tampering with tender forms, or submitting false information/forged documents is a serious offense and will lead to rejection, forfeiture of EMD, and may lead to legal action.

## **6.3. Cost of Bidding**

The bidder shall bear all costs associated with the site visits, preparation and submission of its bid, and NERAMAC shall not be responsible or liable for those costs, regardless of the outcome of the bidding process.

## **6.4. Right to Reject**

NERAMAC may reject a bid if it determines that the bidder has engaged in corrupt, fraudulent, or coercive practices in competing for or in executing the contract. If any information furnished by the bidder is found to be false at any stage, the bid will be rejected and appropriate action (blacklisting, forfeiture of security, etc.) may be taken.

## **6.5. Blacklisting/Debarment**

Any bidder currently debarred or blacklisted by any Central/State government department or public agency is ineligible to participate. If at any time it is found that a bidder has been banned/debarred and has concealed this fact, the tender/contract will be terminated and suitable punitive action will follow.

## **6.6. Integrity Pact**

For high-value tenders, an Integrity Pact may be required to be signed by the bidders, committing to ethical conduct.

## **6.7. Corrigendum and Notifications**

Any corrigendum, clarification, time extension, etc., will be uploaded on the CPPP or state e procurement portal only. The bidders are expected to keep track and consider these for bid preparation. NERAMAC will not send separate communications for such changes.

## **6.8. Tender Cancellation**

NERAMAC reserves the right to cancel the tender at any stage without assigning reason. In the event of cancellation, EMDs will be returned to bidders and no compensation will be payable for any costs incurred by bidders.

## **Important Financial Conditions**

1. The quoted price shall be:
  - **Inclusive of all costs**, including materials, labour, transport, insurance, taxes, and contingencies
  - On a **lump sum EPC basis**

2. The total quoted amount shall:
  - **Not exceed ₹3.50 Crore per location (Inclusive of GST)**
3. No additional payment shall be made for:
  - Any item not explicitly mentioned but required for completion
  - Errors in estimation or omission
4. The bidder shall ensure:
  - Full compliance with DPR requirements for CPC infrastructure
  - Readiness of facility for processing operations

**Note-** “The bidder shall be deemed to have included all components required for successful completion of the Agarwood Processing Plant. Any item not explicitly mentioned but necessary for completion shall be deemed included in the quoted price, and no additional payment shall be admissible.”

## **Section II. Scope of Work**

## 1. Background

The North Eastern Regional Agricultural Marketing Corporation Ltd. (NERAMAC), a Government of India Enterprise under the Ministry of Development of North Eastern Region (DoNER), hereinafter referred to as the "Authority," invites bids from reputed and experienced engineering/construction firms for execution of construction works related to Agarwood Processing Plant(s) under the Agarwood Cluster Development Project in the North Eastern Region of India. The selected agency shall undertake construction of the required infrastructure, including civil, structural, and associated works, in accordance with the approved project requirements and specifications.

This tender is issued for selection of a qualified engineering agency for execution of Agarwood Processing Plant(s) under NERAMAC's Agarwood Cluster Development Project. The scope is focused on execution of civil, structural, and associated infrastructure works for facilities such as Cluster Processing Centres (CPCs), including distillation units, storage infrastructure, processing areas, and quality testing laboratories at designated project locations in Assam and Tripura. The selected agency shall be responsible for engineering & design, complete construction and development of the plant infrastructure in accordance with approved designs. The selected bidder shall be responsible for carrying out the construction in accordance with the approved designs, technical specifications, timelines, and terms & conditions of the contract. No separate empanelment or future assignment mechanism is envisaged under this tender. The award of work under this tender shall constitute a binding contract for execution of the specified construction works.

## 2. Scope of Work

This scope essentially defines a full industrial infrastructure execution package, **where the contractor is responsible for complete engineering and construction** on an EPC mode of contract, based on the preliminary conceptual drawings supplied with this document, delivering a ready-to-use agarwood processing facility (**not just buildings, but an operational-ready plant environment**).

### 2.1. Site Development and Preparation

This is the **pre-construction phase**, critical for ensuring structural stability and long-term durability.

#### What it includes technically:

- **Site clearing:** Removal of vegetation, debris, topsoil stripping
- **Cut & fill operations:** Balancing site levels to achieve design elevations
- **Excavation:** For foundations, trenches, underground tanks
- **Compaction:** Soil stabilization to required bearing capacity
- **Internal roads:** Temporary + permanent access for movement of materials and future logistics
- **Drainage planning:** Essential in North East due to high rainfall (prevents flooding and foundation damage)

## **2.2 Description of Works (Construction of Cluster Processing Centre – CPC)**

The work under this contract involves the **construction and development of Agarwood Cluster Processing Centre (CPC)** at designated project locations in **Golaghat (Assam) and Kadamtala (Tripura)**. The CPC is envisaged as an integrated facility for **collection, storage, processing, distillation, quality testing, and value addition of agarwood products**, ensuring a complete value-chain infrastructure.

The scope of work shall broadly include the following components:

### **2.2.1. Collection and Raw Material Handling Infrastructure**

The CPC shall include facilities for **collection and primary handling of agarwood raw materials** received from growers and producer groups.

Components include:

- Collection counters for receiving agarwood logs and materials
- Initial inspection and weighing areas
- Covered unloading platforms for protection from weather

These facilities shall ensure **organized intake of raw materials** and smooth transition into further processing stages.

### **2.2.2. Storage and Warehousing Facilities**

The contractor shall construct **secure storage infrastructure** for raw materials and intermediate products.

This shall include:

- Raw material warehouse with adequate ventilation
- Secure storage system (locker-based or segregated storage)
- Moisture-controlled storage areas to prevent degradation

The design shall ensure protection against **fungal contamination, moisture damage, and quality loss**, which are critical challenges..

### **2.2.3. Processing and Value Addition Infrastructure**

The CPC shall include dedicated areas for **processing, sorting, grading, and packaging** of agarwood.

Components include:

- Sorting and grading sections for classification of agarwood
- Processing zones for cutting, chipping, and preparation
- Packaging and labeling units

The layout shall be designed to ensure **efficient workflow from raw material to finished product**, minimizing handling losses and improving productivity.

#### **2.2.4. Distillation Unit and Processing Systems**

A key component of the CPC is the **installation-ready infrastructure for agarwood oil extraction** through distillation.

This includes:

- Distillation unit area with heat-resistant flooring
- Provision for steam/hydro distillation systems
- Soaking and pre-processing areas
- Drainage and effluent management systems

The facility shall support **modern distillation processes to enhance oil yield and quality**, addressing inefficiencies in traditional methods highlighted in the DPR.

#### **2.2.5. Quality Testing and Laboratory Infrastructure**

The contractor shall develop a **quality testing laboratory** within the CPC.

This shall include:

- Laboratory space for testing agarwood oil and chips
- Controlled environment for quality analysis
- Electrical and utility provisions for lab equipment

The purpose is to ensure **standardization, compliance with international quality norms, and export readiness** of agarwood products.

#### **2.2.6. Mechanical, Electrical and Plumbing (MEP) Works**

The CPC shall be supported by complete **MEP infrastructure**, including:

##### **Electrical Systems**

- Power distribution systems
- Lighting for industrial and lab areas
- Earthing and safety systems

##### **Plumbing & Water Systems**

- Water supply for distillation processes
- Storage tanks and pipelines

##### **Drainage & Effluent Systems**

- Wastewater disposal systems
- Stormwater drainage

## **Ventilation & Safety**

- Ventilation systems for processing and distillation areas
- Fire safety systems (extinguishers, hydrants, alarms)

These systems form the **functional backbone of the CPC**, ensuring safe and efficient operations.

### **2.2.7. External Development Works**

The CPC shall be developed as a complete industrial campus including:

- Internal roads for movement of raw materials and finished goods
- Storm water drainage (critical due to high rainfall region)
- Boundary wall and security infrastructure
- Utility areas (water tanks, electrical installations)

These works ensure **operational usability and long-term sustainability of the facility**.

### **2.2.8. Integration and Operational Readiness**

The contractor shall ensure that the CPC is delivered as a **fully functional and operational-ready facility**, including:

- Integration of all infrastructure components
- Provision for installation of machinery and equipment
- Readiness for processing operations

The final facility shall support:

- Agarwood chip production
- Oil extraction
- Value-added product processing

### **2.2.9. Compliance and Performance Requirements**

All works shall be executed:

- As per approved designs and technical specifications
- In compliance with applicable BIS standards and safety norms
- Ensuring durability under high rainfall and regional conditions

The completed CPC shall meet the objective of:

- Enhancing value addition
- Improving processing efficiency
- Supporting export-quality production

### 3. Key project Objective-

Upon completion, the infrastructure should enable local processing of bamboo into standardized treated raw material and further into value-added products. The construction should therefore ensure functionality (adequate space, ventilation, lighting for an industrial workshop), durability (structures that can withstand local weather and wear-and-tear of industrial use), and safety (compliance with building and fire safety codes).

#### 3.1 Specific Site Conditions

Tripura & Assam hilly context means some special considerations:

- Earthwork may involve rock or hard soil excavation in some places. Blasting (if required) shall be done only with permission and following safety norms.
- The area experiences long monsoons; hence, the work schedule should consider possible interruptions. However, the contractor must plan for mitigating delays (e.g., stocking materials in advance, working in fair weather windows) as time is of the essence.
- Accessibility: The approach roads are rural and partially earthen; movement of heavy trucks may be challenging. The contractor should survey transportation routes and use appropriate vehicles or improve access temporarily if needed.
- Local Labor: The contractor is encouraged to employ local workers (especially for unskilled work) as available, to generate goodwill and comply with local regulations. However, skilled workers/operators might need to be brought from outside; their accommodation and security must be arranged by the contractor.
- Social Factors: The site may be within a community area. The contractor must maintain good relations with local community, ensure no trespass or damage to adjoining lands, and maintain a clean environment. Proper fencing of work site and signage to keep unauthorized persons away is required for safety.

NERAMAC’s engineers and/or a third-party technical agency will oversee the works. The contractor shall extend full cooperation to them, including allowing access for inspection, testing of materials, and verification of work at any time. The entire scope of work is to be completed within the contract period, and interim milestones may be set (e.g., completion of foundation, completion of shed structure, etc.) to monitor progress.

## 5.2. Project Activities & Timeline

### I. Pre-Construction & Mobilization Stage

Sl. No.	Activity	Description	Time Allowed
I(A)	Site Assessment & Data Collection	Site verification, topography, soil check, review of available inputs (aligned with Construction Estimation activity in PERT)	4 Weeks

I(B)	Detailed Engineering & Design (GFC Drawings)	Preparation of architectural, structural, and MEP drawings required for execution	<b>6 Weeks</b>
I(C)	Cost Validation & Approval	Final cost validation within ₹3.50 Cr ceiling and approval before execution	<b>2 Weeks</b>
I(D)	Contractor Mobilization	Deployment of manpower, machinery, site setup	<b>2 Weeks</b>

**Total Duration: 10–12 Weeks**

## II. Procurement & Pre-Execution Stage

Sl. No.	Activity	Description	Time Allowed
(A)	Procurement Planning	Finalization of material specifications and procurement schedule	<b>2 Weeks</b>
(B)	Material Procurement & Supply	Procurement of construction materials and key components	<b>8–10 Weeks</b>
(C)	Machinery Finalization & Ordering	Finalization and order placement for processing units (if applicable)	<b>8 Weeks</b>

## III. Construction Stage (Core EPC Execution)

Sl. No.	Activity	Description	Time Allowed
(A)	Site Development Works	Clearing, leveling, excavation, internal roads, drainage	<b>6–8 Weeks</b>
(B)	Civil & Structural Construction	CPC building, warehouse, distillation unit structures, admin block	<b>20–24 Weeks</b>
(C)	MEP Works	Electrical, plumbing, drainage, fire safety systems	<b>12–16 Weeks (overlapping)</b>
(D)	External Development Works	Roads, boundary wall, landscaping, utilities	<b>8–10 Weeks</b>

**Total Construction Duration: 36 Weeks (9 Months)**

## IV. Equipment Installation & Integration Stage

Sl. No.	Activity	Description	Time Allowed
IV(A)	Machinery Delivery	Delivery of distillation and processing equipment	<b>8–10 Weeks</b>
IV(B)	Installation & Integration	Installation, utility connections, system alignment	<b>10–12 Weeks</b>

## V. Testing, Commissioning & Trial Run Stage

Sl. No.	Activity	Description	Time Allowed
(A)	System Testing	Testing of electrical, plumbing, and infrastructure systems	2–3 Weeks
(B)	Trial Runs & Calibration	Trial operation of plant systems and readiness validation	2–3 Weeks
(C)	Rectification & Final Readiness	Fixing defects and ensuring operational compliance	1–2 Weeks

**Total: ~6 Weeks**

## VI. Completion & Handover Stage

Sl. No.	Activity	Description	Time Allowed
(A)	Documentation & As-Built Drawings	Submission of drawings, manuals, and reports	2 Weeks
(B)	Final Handover & Certification	Handover of completed CPC and obtaining completion certificates	2 Weeks

**Total: 4 Weeks**

## Overall Project Timeline (EPC Mode)

Stage	Duration
Pre-Construction	10–12 Weeks
Procurement (Parallel)	8–10 Weeks
Construction	36 Weeks
Equipment Installation	20 Weeks (overlapping)
Commissioning	6 Weeks
Handover	4 Weeks

**Total Effective Timeline: 12–14 Months**

# **Section III- General Conditions of Contract**

The following General Conditions of Contract shall form part of the agreement between NERAMAC (the “Employer/Client/Implementing Agency”) and the successful bidder (the “Contractor”). These conditions are aligned with the CPWD Works Manual and general government contract norms, and are to be read in conjunction with the Special Conditions (Section IV), Technical Specifications (Section V), and other contract documents. In case of any ambiguity or discrepancy, the order of precedence of documents shall be:

- (i) Contract Agreement and Addenda,
- (ii) Notice Inviting Tender & Instructions to Bidders,
- (iii) Special Conditions,
- (iv) General Conditions,
- (v) Technical Specifications,
- (vi) Drawings,
- (vii) BoQ/Tentative Schedule of Quantities.

## **1. Definitions:**

### **1.1. Employer/Client**

The North Eastern Regional Agricultural Marketing Corporation (NERAMAC), having its office at NERAMAC Complex, Six Mile, Panjabari Flyover, 781022, acting through its Managing Director or any designated officer, which invites the tender and will employ the Contractor.

### **1.2. Contractor**

The individual or firm (company/proprietor) whose bid has been accepted by the Employer for award of the work and who has signed the Contract Agreement.

### **1.3. Engineer-in-Charge/Competent Authority**

The authorized representative of NERAMAC who will supervise and be in charge of the work. This could be a project engineer or any competent official appointed by NERAMAC to administer the contract.

### **1.4. Work/Works**

All the tasks, construction and services required for the project as described in the tender documents (including Section II: Scope of Work, technical specifications, BoQ, and drawings), to be executed by the Contractor in accordance with the contract.

### **1.5. Contract**

The formal agreement between the Employer and the Contractor for execution of the Work, including all documents listed in the agreement (tender, letter of acceptance, forms, minutes of negotiations, etc.).

## **1.6. Contract Value/Price**

The total price payable to the Contractor for the full and proper execution of the work as per contract terms, as specified in the Letter of Acceptance and Contract Agreement (subject to adjustments for variations, if any).

## **1.7. Site**

The lands and/or places where the work is to be carried out, as well as any other places provided or approved by the Employer for activities connected to the work.

## **1.8. Day and Month**

Calendar day; : Calendar month.

## **1.9. Completion**

The stage when the Engineer-in-Charge/Competent Authority certifies in writing that the works (or a specific part thereof) have been completed in all respects in accordance with the contract and are handed over to the Employer/Client.

## **2. Contract Period and Commencement**

(i) The Contractor shall commence the work at site within 15 (fifteen) days from the date of issue of Letter of Acceptance (LoA) or Work Order, or within the mobilization period specified by NERAMAC. If the Contractor fails to start the work within this period, it will be considered a breach and may lead to action like forfeiture of EMD/PG and cancellation of award.

(ii) The time for completion of the entire work is 9 Months from the start date given in the LoA/Work Order. Time is the essence of the contract. The Contractor shall plan and execute the work strictly to adhere to this timeline. Interim milestones may be set by the Engineer in-Charge/Competent Authority for monitoring progress; the Contractor shall achieve those milestones accordingly.

(iii) If at any point the Contractor's progress is lagging behind schedule or is otherwise inadequate to ensure completion within time, the Contractor must accelerate work as needed (by increasing manpower, working shifts, etc.) at no extra cost, to make up lost time.

## **3. Performance Security (Performance Guarantee)**

(i) The successful bidder shall furnish a Performance Guarantee (PG) in the form of a Bank Guarantee or Demand Draft for an amount equal to 5% of the tendered/accepted value of the work. This PG is distinct from the retention money/security deposit deducted from bills.

(ii) The PG must be submitted within 21 days of issue of LoA (or within the extended period allowed by Employer, maximum 21 days extension with late fee if applicable as per rules). Failure to submit PG on time shall be grounds for cancellation of award and forfeiture of EMD.

(iii) The Performance Bank Guarantee (if furnished) shall be valid up to the stipulated date of completion plus 60 days beyond that. In case the contract period is extended, the PG shall be extended accordingly at contractor's cost.

(iv) The Employer has the right to invoke the PG (in full or part) in the event the Contractor fails to fulfill contractual obligations or for adjustment of any sums due from the Contractor under the contract. The decision of NERAMAC in this regard shall be final.

(v) PG to be furnished in the form of DD/FD should be made in the favour of NERAMAC, payable at Guwahati.

#### **4. Release of PG**

The Performance Guarantee will be released within 60 days after the contractor successfully completes the work in all respects, hands over the completed structures to NERAMAC, and the Defects Liability Period is over, provided all contractual obligations are met. If there are pending claims or defects, appropriate amounts may be withheld.

#### **5. Security Deposit (Retention Money)**

(i) In addition to PG, a Security Deposit (SD) or retention money for due performance of contract shall be deducted from each Running Account (RA) bill of the contractor. A deduction of 5% of the gross amount of each bill will be made as Security Deposit. However, the total SD including EMD should not exceed 5% of contract value (if PG is taken separately) or 10% if no separate PG. (This clause can be adjusted depending on whether PG + retention combined is used, typical CPWD practice is PG 5% + SD 5% making total 10%.)

(ii) The Security Deposit (retention) shall be refunded to the Contractor after successful completion of Defects Liability Period, subject to deduction of any dues/penalties. Alternatively, on request of contractor, the SD may be replaced by equivalent Bank Guarantee after completion of work, to be kept till DLP ends.

#### **6. Advance Payment**

(i) No advance or mobilization advance shall be paid to the Contractor under this contract. The contractor is expected to mobilize resources with own finances.

(ii) Similarly, no secured advance on materials or plant brought to site is payable, unless specifically provided in Special Conditions.

#### **7. Running Bills and Payments**

(i) The mechanism for release of funds shall be in four instalments, each amounting to 25% of the admissible Central share, released based on the tendered cost, and subject to compliance with the prescribed conditions and progress milestones. All completed work will be measured jointly by the Contractor and the Engineer-in-Charge/Competent Authority as per the prescribed mode of measurement in IS 1200/CPWD standards. Measurements and quantities will be recorded in Measurement Books/Sheets. The contractor's representative should sign the measurement records in confirmation.

**(ii) Submission of Bills:**

The Contractor shall submit the RA bill in the standard format, along with supporting measurement sheets and test reports (if any). Each bill should be accompanied by:

- Up-to-date measurements of work done. – Contractor’s signed “Summary of Bill” with gross amount, deductions, and net claim.
- Copies of any site instructions or extra work orders for which payment is claimed.
- Proof of compliance with statutory payments (e.g. wage sheets for labor, EPF/ESI challans) if required by Engineer.

**(iii) Certification & Payment:**

The Engineer-in-Charge/Competent Authority shall check the bill and certify the eligible amount. Payment for certified amount of work will be processed by NERAMAC. One (01) RA bill may be admitted during execution, and the Final bill after completion. Payment shall be made only for actual work executed and certified.

(iv) Payments will be released through NEFT/RTGS to the contractor’s bank account (the contractor must provide bank details and a cancelled cheque as per Annexure-II). All payments are in Indian Rupees. NERAMAC will endeavour to pay within a reasonable time (subjected to release of fund from concerned ministry) after certification of the bill.

(v) Deductions from Bills: The following statutory and contractual deductions will be made from each bill:

- TDS for Income Tax as per prevailing rates.
- TDS for GST if applicable as per GST Act (for works contracts, GST TDS by client may apply).
- Labor Welfare Cess @ 1% (as applicable under BOCW Act).
- Recovery of advance payments, if any, and any adjustments for materials or plant issued by dept.
- Security Deposit @ 5%.
- Any penalties or recoveries due from the contractor under the contract (for example, for delays, deficiencies, or materials supplied by NERAMAC).

(vi) GST Invoices: The Contractor’s bills should be GST-compliant tax invoices showing the GST registration number. The GST amount will be paid only after the Contractor uploads the GST returns and the same reflects in NERAMAC’s GST portal (ensuring the tax has been deposited to the government). The Contractor shall provide proof of GST payment (GST Return or challan) for reimbursement. The responsibility of payment of GST lies with the contractor; NERAMAC shall not be liable for any default.

(vii) Disallowance of Payment: If any work or part of work billed is found substandard or not conforming to specifications during checking or later inspection, the Engineer-in-Charge/Competent Authority can withhold or recover payment for that item until the defect is rectified. Even if payment was made in a previous bill, it can be adjusted in subsequent bills if later defects are noticed.

(viii) Mobilization/Equipment Advances: Not applicable (no advances as stated). If any special case arises where an advance is given, it would be against a BG of equal amount and recovered from bills.

## **8. Schedule of Rates & Payments**

(i) The rates quoted by the bidder are firm and fixed for the entire duration of the contract and the extended period, if any. No escalation or price adjustment will be allowed for any reason (including inflation, material price fluctuation, labor wage increase, etc.), except only if a new tax is imposed or existing tax changed in law, as per GFR provisions.

(ii) The accepted item rates shall be deemed to cover everything necessary for proper execution of the work, including all materials, labor, plant, tools, equipment, transport, taxes, duties, royalties, wastage, and contractor's overheads & profits. The Contractor shall not be entitled to any extra claims outside the BoQ rates except for extra items and variations duly ordered by NERAMAC.

(iii) If any item of work not covered by the BoQ is required to be executed for completion of the project (i.e., an "extra item"), the Engineer-in-Charge/Competent Authority may ask the contractor to do it. The rate for such new item shall be derived from analogous item rates in the contract, or if not possible, then from CPWD Schedule of Rates (DSR) 2023, plus/minus the overall percentage of this tender; or if not available in SOR, then based on market rates with 15% contractor's profit & overhead. The contractor must carry out extra items as instructed; refusal to execute extra items will be treated as breach. Payment for extra items will be certified and paid separately.

(iv) The quantities given in the BoQ are approximate and can vary as per site requirement. The Contractor is bound to execute quantities up to +/- 30% of each item quantity at the same rates. The overall contract value may vary up to +/-30% without change in unit rates. If beyond +/-30%, the rates for the additional quantity beyond 30% may be re-negotiated as per CPWD norms (only if it significantly impacts work, subject to Employer's approval). The Contractor shall not claim extra cost for quantity variations within the +/-30% limit. Payment will be made for actual work done as measured, at contract rates.

(v) If the Employer deletes or reduces any scope of work, the Contractor shall have no claim to anticipated profits or compensation for that. Payment will be made only for work actually executed up to the date the change was ordered.

## **9. Time Management and Progress**

(i) Within 7 days of site-handover, the Contractor shall submit a detailed Work Programme (bar-chart or CPM schedule) for the 18-month period, showing key activities, their durations, sequence, and resource planning. This schedule must be approved by the Engineer-in-

Charge/Competent Authority. The Contractor shall also furnish a cash flow projection and deployment schedule for major equipment and manpower if required.

(ii) The Contractor shall attend periodic site meetings (weekly or bi-weekly as scheduled by Engineer-in-Charge/Competent Authority) to discuss progress. The contractor should submit monthly progress reports with details of work done, planned work, any hindrances, material testing results, etc. Photographs of progress should be provided.

(iii) If the Contractor anticipates any delay beyond their control, they shall forthwith apply in writing for extension of time (EoT) within 7 days of occurrence of such delay, giving reasons, hindrance details, and supporting evidence.

(iv) The Engineer-in-Charge/Competent Authority will analyze the request and if justified, may recommend extension. Extension of time, if granted, will be communicated by the Competent Authority without prejudice to Employer's right to levy LD for any delay that is Contractor's fault. If extension is due to Employer's fault or neutral events, generally LD is waived for that period.

(v) At site, a hindrance register will be maintained to record any hindrances (delays) along with date of occurrence and removal and party responsible. Only hindrances recorded and accepted by Engineer-in-Charge/Competent Authority will be considered for EoT.

(vi) If the Contractor fails to complete the work within the stipulated time (or extended time allowed), Liquidated Damages (LD) shall be levied for the period of delay. LD shall be calculated at 0.5% of the contract value per week of delay (or part thereof), subject to a maximum of 10% of the contract value. This is an agreed pre-estimate of loss and not a penalty. NERAMAC may deduct LD from any payments due or from the Performance Security. LD will be imposed without prejudice to other remedies available (like contract termination).

(vii) **Suspension of Work:** The Engineer-in-Charge/Competent Authority may at any time instruct the Contractor to suspend progress of part or all of the works. The Contractor shall comply and secure the works. If suspension is for reasons not attributable to Contractor, the Contractor will be entitled to time extension (and possibly cost compensation if suspension exceeds a certain period, as per GCC). If suspension is due to Contractor's fault, then no time extension or cost compensation; the Contractor must correct and resume.

(viii) **Foreclosure/Termination by Employer:** If at any time after award, NERAMAC decides to abandon or reduce the scope of work for any reason (such as funds cut, change in policy, etc.), it may do so. A written notice will be given to Contractor. The Contractor shall act accordingly and stop or reduce work. In such case, the Contractor will be paid for the works executed up to the date of notice and reasonable demobilization costs, but not for profits on the portion of work withdrawn. The Contractor shall have no claim for the portion of work not executed or any damages thereof.

## **10. Quality Assurance and Materials**

(i) All materials and workmanship shall conform to the specifications given in Section V and to relevant BIS codes. In absence of explicit specification, the latest CPWD specifications and standards shall apply. Where both BIS and international standards exist, BIS shall take

precedence. The Contractor must ensure the quality of work is as per good engineering practice and standards.

(ii) The Contractor shall submit for approval samples of all materials he proposes to use, and only upon approval shall proceed to procure bulk. All materials (cement, steel, roofing sheets, bamboo components, electrical fittings, etc.) must be of approved make/brand and as per list of approved manufacturers (if provided in specs or by Engineer). Random/regular testing of materials (cement, aggregates, steel, welds, concrete cubes, etc.) shall be done as per quality plan; the Contractor shall provide all assistance for sampling and bear the cost of tests (as per contract or up to certain frequency provided).

(iii) If any material or work is found sub-standard, not meeting specifications or drawings, the Engineer-in-Charge/Competent Authority can reject it. The Contractor must remove all rejected materials from site and redo/replace defective work at his own cost, without any time/cost compensation.

(iv) For a project of this scale, a small site lab with basic testing apparatus (sieve sets, cube molds, slump cone, weighing scale) should be set up by the Contractor for routine tests. Otherwise, tests shall be conducted at external labs as directed.

(v) NERAMAC and its authorized representatives (or third-party quality monitors) have full power to inspect any portion of work, ask for tests, and review quality. The Contractor shall provide them access, cooperate, and provide necessary instruments (like ladders, scaffolding, tools) for such inspection. No part of the work shall be covered up or put out of view without approval; adequate notice must be given to Engineer-in-Charge/Competent Authority whenever a segment is ready for inspection (especially structural foundations, reinforcement, etc. before concreting). The Engineer's decision on quality is binding.

(vi) The Contractor is responsible for the safety of all personnel on site, the works, and the general public in vicinity. All necessary safety measures shall be taken as per standard practice:

– Workers must be provided with Personal Protective Equipment (PPE)

– helmets, safety shoes, safety belts (for height work), gloves, masks, etc. and must use them at site at all times. – For any hot works like welding, proper precaution to prevent fires. Fire extinguishers shall be kept on site

. – Trenches or excavations must be barricaded and lit at night. Proper signage (Danger, No entry, PPE required etc.) should be installed.

– The Contractor shall be solely responsible for any accidents, mishaps, or incidents at the site. The Contractor shall, at his own cost, obtain and maintain valid insurance coverage throughout the contract period, including Contractor's All Risk (CAR) Insurance for the full value of the works (covering loss or damage to works, materials, and equipment due to external factors), Third Party Liability Insurance for any third-party injury or property damage, and Workmen's Compensation Insurance or employee insurance as required under applicable laws for all personnel deployed at site.

– The Contractor shall ensure that all such insurance policies remain valid and effective for the duration of the works. Submission of insurance policy copies to NERAMAC shall not be mandatory; however, the Contractor shall be fully liable for settlement of all claims, damages, or compensation arising from any incident. NERAMAC shall be fully indemnified against any liabilities, claims, or losses arising out of or in connection with the execution of the works.

(vii) The Contractor shall keep the site clean and tidy during execution. Remove debris periodically to avoid clutter (either use designated dumping areas or dispose of outside as per local rules). After completion, all temporary structures, excess materials, debris etc., must be removed and site handed over in neat condition.

## **11. Labor Laws and Employment**

(i) The Contractor shall abide by all applicable labor laws/regulations, including but not limited to the Contract Labour (Regulation & Abolition) Act, Building and Other Construction Workers (BOCW) Act, Minimum Wages Act, EPF & MP Act, ESI Act, Payment of Wages Act, Child Labor (Prohibition) Act, etc.

(ii) The Contractor must register under BOCW Act and ensure the workers are provided necessary welfare measures. Contribution of cess @1% on the project cost towards the 24 Building Workers Welfare Board will be deducted from bills and remitted by NERAMAC as per law.

(iii) No child labor or underage workers shall be employed. Workers should be above 18 years.

(iv) Wages to workers must be paid on time (at least every month or as per law) and not less than minimum wages notified for that category in that region.

(v) The Contractor shall maintain records like muster roll, wage register, attendance, etc., and make them available for inspection by authorities.

(vi) Proper facilities at site for workers: drinking water, first aid, rest shed, and toilets (temporary) should be provided by Contractor. In case of labor camps, ensure decent living conditions.

(vii) The Contractor must immediately notify the Engineer-in-Charge/Competent Authority and competent authorities in event of any serious accident or fatality at site. All expenses for medical treatment or statutory compensation to workers (or public) due to construction activity shall be borne by Contractor.

(viii) The Contractor shall indemnify NERAMAC from any liability arising on account of any violation of labor laws or accidents.

## **12. Site Organization and Responsibility**

(i) The Contractor shall designate a competent Project Manager / Site Engineer to represent him at site, who will be responsible for all coordination, receiving instructions, and managing

day-to-day work. This person should be empowered to take decisions and issue receipt for instructions on behalf of Contractor.

(ii) The Contractor's site team shall include qualified technical staff (civil engineer, etc.), a safety supervisor, and adequate foremen for different trades. Lack of sufficient technical staff will be treated as non-compliance and can lead to action by Engineer-in Charge/Competent Authority.

(iii) The Contractor shall not sublet the whole work. However, certain specialized works can be executed through subcontractors with prior approval of NERAMAC (e.g. electrical, fabrication). The main contractor remains responsible for quality and progress of subcontracted works. The list of proposed subcontractors (if any) should be submitted for approval.

(iv) The Contractor is fully responsible for the actions of all personnel on site, including any subcontractors or suppliers. Any misconduct, theft, or nuisance by contractor's staff can lead to their removal from site on instruction of Engineer-in-Charge/Competent Authority.

(v) If other contractors or agencies to work simultaneously or install something at site, the Contractor shall cooperate and not hinder their work. NERAMAC may adjust schedules to avoid clashes. The Contractor must provide necessary access/scaffolding to other agencies if needed for project's interest.

### **13. Measurement and Billing**

(i) Measurement of works will be done as per standard practice:

- Length in running meters (m), areas in square meters (sqm), volumes in cubic meters (cum), weight in kg or tonne for steel, etc., as specified by the item.
- If there is any dispute on measurements, the decision of Engineer-in Charge/Competent Authority will be final, but contractor can witness and countersign measurements.

(ii) For hidden items (foundations, reinforcement), measurements must be recorded jointly before pouring concrete or covering up. The contractor must ensure presence at measurement failing which the measurements taken by Engineer will be binding.

(iii) Final Bill: Within 60 days of the date of completion of the work and handing over, the Contractor shall submit the final bill along with all supporting documents, completion drawings, test reports, and a No Claim Certificate. No claims will be entertained after submission of final bill except those mutually recorded as unsettled.

(iv) The Final bill will be processed after verifying that:

- All defects noted in site inspections are rectified.
- All surplus materials, debris are removed; site is clear.
- All recoveries (advances, penalties, etc.) are accounted.
- The contractor has submitted all warranties (for waterproofing, etc.), manuals, and as-built drawings as required.

(v) **No Claim Certificate:** The Contractor's final bill must include a written undertaking that they have no further claims or demands other than what is claimed in the final bill, and that they accept the final payment in full and final settlement of the contract.

(vi) Payment of final bill shall not discharge the contractor from DLP obligations. Some amount may be withheld from final bill if any particular work's performance is to be seen in some season (like monsoon effect on drainage), otherwise usually covered by PG and DLP provisions.

#### **14. Defect Liability and Warranty**

(i) The completed work will be under a Defects Liability Period (DLP) of **12 (twelve) months** from the date of handing over to NERAMAC. The contractor shall be responsible to make good, at his own expense, any defect, shrinkage, settlement or other faults in the work that appear during this period due to defective or improper workmanship or materials.

(ii) NERAMAC will give the contractor notice of observed defects and the Contractor must rectify the same within a reasonable time (as instructed, typically within 7 to 15 days depending on defect). If the contractor fails to do so, NERAMAC reserves the right to get it rectified by others and recover the cost from the contractor or from the Performance Security/retention.

(iii) Typical defects might include: roof leakage, paint failure, structural distortion, door/window malfunction, electrical shortfall, plumbing leak, etc. The contractor should attend to all such issues promptly.

(iv) The DLP may be extended in respect of portions of work that get repaired or replaced, from the time of such repair.

(v) At the end of DLP, if no defects remain or all attended, the Security Deposit/retention and any remaining PG will be returned to the contractor.

(vi) Additionally, any specific warranties provided by manufacturers for products should be transferred to the Employer in writing at completion.

#### **15. Additional Obligations of Contractor**

(i) The contractor shall comply with all local, state and central laws regarding environmental protection, waste disposal, work hours, mining of materials. Any liability or penalty arising from non-compliance will be borne by the contractor.

(ii) NERAMAC will assist with any letters for obtaining permits but it is primarily the contractor's duty to obtain any required work permits, quarry permits, explosive licenses (if blasting) etc.

(iii) If the work or material transport affects public roads, the contractor must coordinate with local authorities to manage traffic. Proper barricading, flagmen, and safety measures on public roads shall be employed during transport of materials or construction near roadways.

(iv) The contractor shall protect the work from damage by weather, floods, fire, etc. until handover. If any such damage occurs, the contractor must repair at own cost. The contractor is also liable for any damage to existing structures or utilities in or around the site. For example, if there's an existing building or underground cable adjacent, the contractor must work carefully and if any damage happens, restore it.

(v) The contractor will do the setting out of all works using established reference points. He must construct any temporary access roads, staging, scaffolding, centering needed for the works and remove the same after use. The quality of temporary works should be such that they are safe.

(vi) If government inspectors (labor officers, electrical inspector, etc.) visit for compliance checks, the contractor shall extend full cooperation and take immediate corrective measures if any issues pointed out.

## **16. Contract Amendments & Variations**

(i) No variation or modification of the terms of the contract shall be made except by written amendment signed by both parties. NERAMAC has the right to instruct variations within the general scope, and the Contractor shall carry them out. Variation might include changes in design, quantities, or sequence. The effect on cost and time will be mutually agreed or determined by Engineer based on contract rates principles.

(ii) The Contractor shall not suspend work on variation orders pending resolution of payment, provided the variation is formally ordered. Interim rates can be certified and adjusted in final bill if needed.

## **17. Breach, Default, and Termination**

(i) Termination for Default: If the Contractor: – fails to start the work or achieve satisfactory progress, or

– abandons the work, or

– fails to adhere to the agreed schedule and 15 days' notice to catch up has been given but no improvement, or – breaches any material term of contract (like persistent safety violations, non payment of workers), or

– has been found to have given false information at bid stage, then NERAMAC may issue a Show Cause Notice outlining the defaults. If the Contractor does not take effective corrective action within 15 days (or specified period) of notice, NERAMAC may issue a Termination Notice and terminate the contract forthwith.

(ii) Upon such termination, the Performance Security and any retention monies can be forfeited. NERAMAC can then get the balance work executed by alternate means. If the alternate arrangement costs more than the balance contract value, the difference in cost shall be recoverable from the defaulting contractor.

(iii) The Contractor will be paid for the portion of work satisfactorily completed up to termination, as certified, after adjusting any additional costs due to the breach. The contractor will have no claim for the remaining work or any compensation.

(iv) Termination for Convenience: The Employer can terminate without cause with appropriate notice. The contractor gets paid for work done and demobilization as per contract terms, but no further claims allowed.

(v) Contractor's right to terminate: If the work is continuously suspended by NERAMAC for more than 3 months for reasons not attributable to Contractor or if payments due to contractor are excessively delayed despite reminders, the contractor may issue notice to NERAMAC. If problem not resolved within 30 days, contractor can terminate. In such case, contractor to be paid for work done plus reasonable demobilization cost, and Performance Security returned. However, this situation is rare and will be handled case-by-case.

(vi) Debarment: In the event of termination for contractor's default, NERAMAC reserves the right to debar the contractor from participating in future tenders for a certain period, depending on severity of non-performance.

## **18. Liability and Indemnification**

(i) The Contractor shall indemnify and hold harmless the Employer, its employees and agents from any and all suits, actions or administrative proceedings, claims, demands, losses, damages, costs, and expenses of any nature arising out of the work including those in respect of injury to persons or damage to property arising from the actions or omissions of the Contractor, its employees, agents, or subcontractors in performance of the contract.

(ii) This clause survives the contract termination.

## **19. Dispute Resolution**

(i) Arbitration: Except as otherwise provided in the contract, if any dispute or difference arises between the Employer and the Contractor in connection with this contract, they shall first attempt to resolve it amicably by mutual discussion. If unresolved, the dispute shall be referred to Arbitration in accordance with the Arbitration and Conciliation Act, 1996 (and amendments). A sole arbitrator shall be appointed by the NERAMAC (with consent of both 28 parties). If the arbitrator so appointed resigns or is unable to act, NERAMAC will appoint another arbitrator.

- The arbitrator can be an NERAMAC official (even one who has knowledge of the project)
- No party shall object to the arbitrator on grounds that he is or was an employee of NERAMAC.
- The venue of arbitration shall ideally be Guwahati (unless both parties agree to a different place).
- The arbitration proceedings shall be in English.
- The award of the Arbitrator shall be final and binding on both parties. The arbitrator shall give speaking awards with reasons and may award costs.

– During the pendency of arbitration, the Contractor shall, as far as reasonably possible, continue to perform the work and maintain progress, and the Employer shall continue to make payments for undisputed items.

(ii) **Exclusions from Arbitration:** Matters where the decision of Engineer-in-Charge or NERAMAC is stated in the contract to be final and binding, shall not be open to arbitration. Also, disputes with Government regulatory bodies or other external agencies are outside this scope.

(iii) **Jurisdiction:** Subject to arbitration clause, in case a legal intervention or court proceeding is required, it shall be under the jurisdiction of competent courts in Assam (the High Court at Guwahati). No court jurisdiction is acceptable other than Assam for this contract.

## **20. Force Majeure**

(i) If the work is delayed or prevented due to events beyond the control of the Contractor and Employer, such as war, riots, civil unrest, earthquakes, floods, pandemic outbreaks, lockdowns, government restrictions, or other Force Majeure Events, neither party shall be held in breach of the contract for such non-performance. Upon the occurrence of a Force Majeure Event, the affected party must notify the other party within 21 days describing the event and its impact.

(ii) The obligations under the contract shall be suspended to the extent and for the time duration the Force Majeure persists. An extension of time for completion shall be granted equivalent to the period of the Force Majeure impact. No financial compensation is payable for idle time due to Force Majeure.

(iii) Examples: Unprecedented flood washing away approach roads, or government order to halt work due to a pandemic, etc., will qualify as Force Majeure. Normal monsoon rains or predictable weather, or financial distress of the contractor, do not count as Force Majeure.

(iv) If a Force Majeure event is of such magnitude that it effectively voids the purpose of contract or makes completion impossible within reasonable time, both parties will consult to decide whether to continue or terminate the contract. If terminated due to prolonged Force Majeure, the contractor is paid for work done up to that point and demobilization; neither party has further claim on the other.

(v) Force Majeure shall not include delays caused by lack of materials or personnel (unless due to a general strike or national lockdown), or rain/lightning unless abnormally beyond historical patterns.

## **21. Change in Law**

(i) If after the bid opening and before completion of contract, any law, regulation or ordinance of India is enacted, repealed or changed such that it affects the contractual obligations or payments, the contract price shall be adjusted accordingly to reflect the impact. For example, if GST rate increases, the increased tax will be paid by Employer (as it is reimbursable), if GST decreases, the benefit goes to Employer.

(ii) The Contractor must inform NERAMAC in case any such change in law affects costs. Proper documentation of the change will be required for any claim.

## **22. Electronic Communication Validity**

(i) As much of the correspondence in modern contracts is done via email or electronic portal, it is agreed that official communications made through email (to designated email addresses of the parties) shall be considered valid and binding. If NERAMAC issues an LoA or instruction through email, the date/time of the email will be considered the official issuance date. However, critical communications may be followed by hard copy for record. Both parties shall ensure they maintain active communication channels.

(ii) The e-procurement portal communications (e.g., issue of corrigendum, online queries, etc.) are also considered official mode.

## **Section IV: Special Conditions of Contract (SCC)**

These Special Conditions shall be read in conjunction with the General Conditions (Section III) and shall prevail in case of any conflict. The SCC cater to project-specific and location-specific requirements for the Agarwood Cluster Processing center project.

## **1. Work in Remote Area-**

Golaghat, Assam and Kadamtala, Tripura is a remote district with limited urban facilities. The contractor should make thorough logistical plans for working in this remote area:

(i) **Approach Roads:** The road leading to the site is partly narrow and winding. Transportation of heavy and long materials may require smaller trucks or careful routing. The contractor must survey the route in advance and, if necessary, coordinate with local authorities for movement of oversize loads. Any road damages caused by contractor's transport must be repaired by the contractor at own cost.

(ii) **Staging of Materials:** Due to distance from major markets (Guwahati or Agartala are nearest big supply centers), the contractor should stockpile critical materials (cement, steel, etc.) in sufficient quantities at site or nearby storage. Particularly before the monsoon season, enough materials should be brought in to avoid work stoppage when roads may become difficult.

(iii) **Climate Considerations:** The region sees heavy rainfall typically from June to September. Work like excavation and concreting should be planned in drier months if possible. During monsoon, ensure precautions: dewatering pumps on standby, tarpaulins to cover cement and work areas, temporary drains to channel rainwater, etc. Any partially done work must be secured each day to prevent damage from overnight rains. Rain or normal bad weather will generally not qualify for time extension, being a known seasonal factor, unless rainfall is extraordinarily above average causing floods or landslides (considered force majeure in extreme case). The contractor is expected to factor in typical rain delays in their scheduling.

(iv) **Working Hours:** By default, work can be carried out in daylight hours. Working after sunset may be challenging due to lack of power and community noise concerns. If night work is required (e.g. for concreting large pours), contractor must arrange proper lighting and get prior permission from Engineer-in-Charge/Competent Authority. Also consider that during certain local festivals or events, work might need slowing down as advised by community; coordinate with local administration if needed.

## **2. Local Conditions and Coordination**

(i) **Community and Security:** It's important to maintain good relations with the local community. The Contractor should preferably hire some local labor to involve the community. If any community structures (like village road or water line) are disturbed during construction, the contractor must restore them or provide alternatives in consultation with locals.

(ii) There have been occasional law and order issues in remote NE regions. The contractor should keep the local police and Council authorities informed of their presence. All contractor staff should carry proper ID and preferably be registered at nearest police station for security reasons.

(iii) **Forest and Environment:** The region is ecologically sensitive with significant forest cover. The contractor must not cut trees or clear vegetation beyond the construction footprint without explicit permission. If tree cutting is unavoidable for site access or building footprint, necessary approvals must be obtained through NERAMAC from Forest Dept and compensatory plantation carried out. No hunting or fishing by laborers is permitted; instruct your workforce to respect local wildlife and habitats.

(v) **Heritage/Cultural Consideration:** If during excavation any artifact or archaeological find is discovered, work should stop and NERAMAC informed immediately to take guidance from authorities.

### **3. Utilities and Site Facilities**

(i) **Water Supply:** Potable water might not be readily available at site. The contractor may need to drill a borewell or bring tanker water from nearest source for construction. Water for construction must be of acceptable quality. Testing of water should be done at the start. For workers' drinking needs, filtered water must be provided.

(ii) **Electricity:** Grid power at site could be limited or not present. The contractor should be prepared to deploy diesel generators for construction power. If a temporary electrical connection from state electricity board is feasible, the contractor may apply for one with support of NERAMAC. All electrical wiring done for construction must be safe, use proper cables, ELCB, and no loose live wires. After work, temporary connections must be removed.

(iii) **Contractor's Site Establishment:** The contractor can erect a temporary site office, stores, and labor camp on the land allocated by NERAMAC. These must be neat and as per safety norms. Local building materials may be used for huts but ensure they withstand wind and rain. The labor camp must have toilets to prevent open defecation in the area, and grey water should be disposed properly to avoid mosquito breeding.

(iv) **Explosives Use:** If rock blasting is required for leveling or foundation, the contractor must obtain appropriate license and strictly follow controlled blasting techniques. Inform local residents in advance, use small charges, and ensure qualified blasters handle it. Mats or cover should be used to prevent fly-rock. Adhere to timing restrictions (usually blast in midday when public activity is least). Any damage due to blasting is contractor's liability.

### **4. Design and Technical Particulars**

(i) **Technical Particulars and Approved Designs** are being provided at Section V & Section VII respectively.

### **5. Testing and Completion**

(i) **Site Tests:** Special conditions require that prior to handing over, certain performance tests be done: 33 – Water tightness test for roofing (visual inspection during heavy rain to ensure no leaks).

– Drainage test (if applicable, pour water to check flow).

– Electrical insulation test for wiring (megger test).

- Earth resistance test for earthing (should be < 5 ohm ideally).
- Functional test of all fixtures (lights, fans, plumbing) in presence of Engineer/Competent Authority.

**(ii) Clearances:**

The contractor shall obtain necessary clearances post-construction:

- Electrical Inspectorate clearance for new electrical installations (if required under state rules for the load installed).
- Fire safety clearance, if required (for an industrial shed of this size, not usually mandatory, but ensure basic firefighting equipment like extinguishers are installed by the contractor at handover).
- Occupancy/Completion Certificate: Not typically needed as it's not a public building, but if any local body approval was taken for construction, ensure completion certificate is obtained.

**(iii) Training:**

The special conditions may require the contractor to provide basic training to NERAMAC/local staff on maintenance of the building. For instance, how to operate rolling shutters, maintenance of roofing (cleaning gutters), and any specific coating reapplication for bamboo, etc. The contractor should also hand over a maintenance manual listing all finishes and manufacturer recommendations for upkeep.

**(iv) Spare Materials:**

The contractor should budget to supply some spare materials at handover, such as matching paint, touch-up paint, a few light fittings, etc., for future maintenance by the client. (If any specific spares are required, it will be mentioned in specifications or instructed by the Engineer/Competent Authority.)

**6. Environmental and Social Responsibility**

**(i) Waste Management:**

The contractor must manage construction waste properly. No construction debris should be left scattered. Usable excess earth can be used to level low areas or create noise bunds if needed; otherwise, it should be neatly spread. Waste concrete or steel scrap should be collected—scrap steel to be stacked for disposal, and concrete waste can be broken and used in fillings for access tracks. All debris must be cleared before final cleaning.

**(ii) Dust and Pollution Control:**

During dry seasons, dust may arise from excavation or vehicular movement. Water should be sprinkled on haul roads to suppress dust when needed. Vehicles carrying fine materials (sand, cement) should be covered. The contractor's machinery should be in good condition to minimize excessive smoke or oil leaks.

**(iii) Noise:**

Work generating heavy noise (e.g., rock breaking) should be done during daytime and not too early or late to avoid disturbing locals. If any schools or institutions are nearby, coordinate noisy work timing with their working hours if required.

**(iv) COVID-19 / Health Measures:**

If any epidemic/pandemic guidelines are in place (e.g., COVID-19 protocols), the contractor shall follow all government advisories, including providing masks, maintaining distancing, and ensuring site sanitization. A medical first aid kit must be available on-site at all times.

**7. Miscellaneous**

**(i)** The contractor should note that an 18-month timeline in hilly terrain is reasonable but tight; therefore, efficient planning is vital. Mobilization should be immediate upon award. Idle periods must be avoided. NERAMAC expects the contractor to utilize initial fair-weather months to complete major civil and structural works, leaving finishing and services (which are less weather-dependent) for later stages.

**(ii)** Any deviation by the contractor from drawings/specifications must have prior approval. Unauthorized changes may have to be dismantled at the contractor's cost if not approved.

**(iii) Site Photographs:**

The contractor shall maintain a photographic record of progress. These shall be submitted with bills or in reports. This helps in resolving any later disputes on hidden works and provides documentary evidence of work stages.

**(iv) Agarwood Product Integration:**

Since the project is thematically based on Agarwood, the Employer may arrange or request the contractor to accommodate visits by officials or the press to demonstrate progress. The contractor should ensure site safety during such visits and assist in showcasing the work if required. This is not a regular requirement; however, the contractor should be open to facilitating such events (NERAMAC will coordinate timing to avoid disruption of work).

**(v) Handing Over:**

After completion, a joint inspection will be conducted. The contractor shall rectify any pending snag points identified. The site shall then be formally handed over through a written Handing/Taking Over Certificate signed by both parties.

**SECTION V- BID EVALUATION STAGE**

1- The evaluation of bids shall be carried out in a **two-stage process**, comprising **Technical Qualification (Pass/Fail basis)** followed by **Financial Evaluation (L1 basis)**, to ensure selection of a **technically qualified and financially competitive EPC contractor** for execution of the Agarwood Processing Plant (CPC).

### 1.1- Stage-I: Technical Evaluation (Qualification Stage – Pass/Fail)

All bids shall first be evaluated to determine compliance with the prescribed **Eligibility Criteria (Section 3)**. This stage is intended to ensure that only **technically capable, financially sound, and regionally experienced bidders** are considered for further evaluation.

#### Evaluation Methodology

- Each criterion shall be evaluated on a **Pass/Fail basis**
- The bidder must meet **all mandatory eligibility requirements**, including:
  - Legal status
  - Financial capacity
  - Technical experience
  - **Mandatory North East experience (Assam/Tripura preferred)**
  - Equipment availability
  - Statutory compliance
  - Technical manpower

#### Technical Evaluation Sheet

Sl. No.	Criteria	Requirement	Documents Required	Status (Pass/Fail)
1	Legal Status	Registered entity	Incorporation, PAN, GST	
2	Turnover	Avg. $\geq$ ₹30 Cr	CA Certificate	
3	Net Worth	$\geq$ ₹5 Cr	CA Certificate	
4	Bank Solvency	$\geq$ ₹10 Cr	Bank Certificate	
5	Experience	3 projects $\geq$ ₹2 Cr	Work Orders + Completion	
6	Regional Experience <b>(Mandatory)</b>	$\geq$ 1 project in North East (Assam/Tripura preferred)	Work Order + Completion Certificate	
7	Equipment	Required machinery available	RC / Invoice	
8	Compliance	Not blacklisted	Self Declaration	
9	Manpower	Qualified Civil Engineer MEP Engineer	CV / Proof	

## Qualification Rule

- The bidder shall be declared **Technically Qualified** only if all criteria are marked **PASS**
- Failure to meet **any one criterion** shall result in **rejection of the bid**
- No partial compliance shall be accepted

## 1.2 Stage–II: Financial Evaluation (L1 Selection)

Financial bids of only those bidders who are declared technically qualified shall be opened and evaluated.

## Evaluation Methodology

- The bidder quoting the **lowest evaluated price (L1)** shall be considered for award of contract
- Price evaluation shall be based on:
  - Total quoted EPC cost for the project
  - Compliance with cost ceiling (₹3.50 Crore per location – Inclusive of GST)

## 2- Special Financial Provisions

### 2.1. Abnormally Low Bid

NERAMAC reserves the right to seek detailed justification from bidders quoting **abnormally low prices**. If the justification is found unsatisfactory, the bid may be rejected as per applicable provisions of Government procurement rules.

### 2.2 Price Reasonability

NERAMAC may also assess whether the quoted price is:

- Unrealistically low (execution risk), or
- Excessively high (non-competitive)

### 2.3. Conditional Bids

- Conditional or incomplete financial bids shall be **rejected**

## 3-Final Selection

- The contract shall be awarded to the **Lowest (L1) Technically Qualified Bidder**, subject to:
  - Verification of documents
  - Acceptance of contract conditions
  - Compliance with all tender requirements

#### **4-Rights of NERAMAC**

NERAMAC reserves the right to:

- Verify credentials and past performance
- Seek clarifications from bidders
- Reject any or all bids without assigning reasons
- Cancel or modify the tender process at any stage

**Section VI: Infrastructure Specification &  
Preliminary Conceptual Drawings of Tripura and  
Assam (Annexure IV & V)**

# Infrastructure Specification

Sl. No.	Component	Description of Works	Key Requirements / Specifications
1	<b>Site Development</b>	Clearing, leveling, grading, and preparation of land	Proper slope, no waterlogging, suitable for construction and movement
2	<b>Internal Access &amp; Circulation</b>	Development of internal roads and pathways	Smooth movement of vehicles and materials within site
3	<b>Storm Water Drainage</b>	Drainage system across site	Designed for high rainfall conditions of North East region
4	<b>Main Processing Building (CPC)</b>	Industrial building for processing and distillation	RCC/PEB structure, adequate height, ventilation, industrial flooring
5	<b>Raw Material Storage (Warehouse)</b>	Storage facility for agarwood logs	Moisture protection, ventilation, easy material handling
6	<b>Distillation &amp; Processing Area</b>	Dedicated area for distillation units and processing	Heat-resistant flooring, drainage, ventilation for fumes and vapors
7	<b>Sorting, Grading &amp; Packaging Area</b>	Space for post-processing operations	Clean layout, proper workflow design, adequate lighting
8	<b>Administrative Block</b>	Office and control area	Functional office space, basic staff facilities
9	<b>Utility Facilities</b>	Toilets, rest area, service spaces	Basic amenities for workers and staff
10	<b>Electrical System</b>	Power distribution and lighting	Panels, internal/external wiring, earthing and safety systems
11	<b>Water Supply System</b>	Water storage and distribution	Adequate supply for processing and domestic use
12	<b>Drainage &amp; Effluent System</b>	Wastewater and liquid discharge system	Proper disposal and flow management
13	<b>Ventilation / Environmental Control</b>	Air circulation systems	Adequate ventilation for processing and working conditions
14	<b>Fire Safety System</b>	Fire protection infrastructure	Fire extinguishers, firefighting arrangements as per norms
15	<b>Processing Infrastructure Readiness</b>	Infrastructure for installation of machinery	Machine foundations, platforms, utility connections
16	<b>Quality Testing Laboratory</b>	Lab for testing agarwood oil and products	Controlled space, electrical and utility provisions
17	<b>External Roads &amp; Pathways</b>	Internal circulation network	Durable surface for logistics and operations
18	<b>Boundary Wall / Fencing</b>	Site security infrastructure	Defined boundary and restricted access
19	<b>Entry &amp; Exit Gates</b>	Controlled access points	Properly designed entry/exit for vehicles and personnel
20	<b>Landscaping &amp; Site</b>	Basic landscaping and	Environmental improvement and

	<b>Finishing</b>	finishing works	site usability
21	<b>Utility Infrastructure Areas</b>	Space for tanks, panels, service equipment	Organized placement of utilities
22	<b>Design &amp; Engineering</b>	Preparation of all drawings and designs	Architectural, structural, MEP as per BIS/NBC standards
23	<b>Construction Quality</b>	Execution of works	Approved materials, proper workmanship, compliance with standards
24	<b>Testing &amp; Commissioning</b>	Testing of all systems	Electrical, plumbing, drainage to be fully functional
25	<b>Operational Readiness</b>	Final readiness of facility	Infrastructure ready for agarwood processing operations
26	<b>Final Deliverables</b>	Handover of completed project	As-built drawings, documentation, complete facility

**BILL OF QUANTITIES (BOQ) BASED ON PRELIMINARY CONCEPTUAL DRAWINGS**  
**CIVIL WORKS (DSR 2023)**

SN	SOR Item No.	Item Description	Unit	Qty
1	DSR 2.8.1	Earth work in excavation by mechanical/manual means in foundation trenches/drains, including dressing, ramming, disposal etc. – All kinds of soil	Cum	735.00
2	DSR 2.25	Filling available excavated earth in trenches, plinth, sides of foundation etc.	Cum	475.00
3	DSR 2.25(a)	Excavating, supplying and filling local earth including ramming and watering	Cum	346.80
4	DSR 2.35.3	Treatment of soil under floors using chemical emulsion (Chlorpyrifos/Lindane)	Sqm	782.00
5	DSR 5.9.1	Centering and shuttering – Foundations, footings etc.	Sqm	512.30
6	DSR 5.9.5	Centering and shuttering – Lintels, beams, girders etc.	Sqm	314.65
7	DSR 5.9.6	Centering and shuttering – Columns, pillars etc.	Sqm	225.40
8	11.2	Dry brick on edge flooring	Sqm	1650.00
9	DSR 4.1.5	PCC 1:3:6 up to plinth level	Cum	189.25
10	DSR 4.10	Damp-proof course 40 mm thick	Sqm	65.00
11	DSR 5.1.2	RCC work up to plinth level	Cum	165.52
12	DSR 5.2.2	RCC work in walls above plinth	Cum	27.20
13	DSR 5.3	RCC work in beams, slabs, etc.	Cum	29.76
14	DSR 5.22.6	Steel reinforcement for RCC work	Kg	19764.20
15	DSR 11.3.1	Cement concrete flooring 40 mm thick	Sqm	784.00
16	DSR 6.1.1	Brick work in foundation and plinth (CM 1:4)	Cum	97.56
17	DSR 6.13.1	Half brick masonry in superstructure	Sqm	463.10
18	DSR 13.4.1	12 mm cement plaster (1:4)	Sqm	1050.50
19	DSR 13.8.2	15 mm cement plaster (1:4)	Sqm	986.70
20	DSR 13.44.1	Exterior finishing with waterproof cement paint	Sqm	1005.20
21	DSR 13.80	White cement based putty	Sqm	347.00
22	DSR	Wall painting with acrylic emulsion (two coats)	Sqm	314.50

	13.82.2			
23	DSR 13.48.3	Painting steel work	Sqm	642.00
24	DSR 9.5.2.1	Wooden door shutters (35 mm thick)	Sqm	20.20
25	DSR 12.50	Pre-coated GI profile sheet roofing	Sqm	2865.50
26	DSR 12.51.1	Roofing accessories – ridges	Rm	108.00
27	DSR 12.51.4	Roofing accessories – barge board	Rm	75.00
28	DSR 10.16.1	Structural steel work in tubular sections (trusses etc.)	Kg	42521.00
29	DSR 10.5.1	MS sheet doors with frame	Sqm	20.20
30	DSR 13.10	15 mm cement plaster (1:3)	Sqm	262.00
31	DSR 21.1.1.2	Aluminium work – fixed portion	Kg	189.70
32	DSR 21.1.2.2	Aluminium work – shutters	Kg	135.60
33	DSR 21.2.2	Pre-laminated particle board paneling	Sqm	143.00
34	DSR 21.3.2	Glazing with 5 mm glass	Sqm	70.00
35	DSR 12.58.1	False ceiling (calcium silicate board)	Sqm	195.00
36	DSR 11.41.2	Vitrified floor tiles (600x600 mm)	Sqm	216.00
37	DSR 8.31	Ceramic glazed wall tiles	Sqm	57.00
38	DSR 4.17	Plinth protection	Sqm	247.00
39	DSR 10.3	Collapsible steel shutters	Sqm	48.00
40	DSR 23.11.3	Borewell ERW slotted pipe (200 mm dia)	Rm	150.00
41	DSR 18.9.10	CPVC pipes (150 mm dia)	Rm	150.00
42	DSR 18.48	Water storage tank (10,000 litre)	Ltr	10000.00
43	PAR 5.8.1	Boundary wall with MS grill and gate	Rm	205.00
44	DSR 16.68	Interlocking paver blocks (M30 grade)	Sqm	496.00

## **Section VII- Forms and Annexure**

## Form-I

### Bid Submission / Acceptance Letter

To,  
The Managing Director,  
**North Eastern Regional Agricultural Marketing Corporation Ltd. (NERAMAC)**  
NERAMAC Complex, Six Mile,  
Near Panjabari Flyover,  
Guwahati – 781022

**Sub:** Bid Submission for “Construction of Agarwood Processing Unit in Assam (Goalghat) and Tripura (Kadamtala)” – Acceptance of Terms & Conditions of Tender

Dear Sir/Madam,

I/We, the undersigned, hereby declare and confirm as follows:

(a) I/We have downloaded/obtained the tender documents for the above-mentioned work and have carefully examined all the documents forming part of the tender.

(b) I/We hereby certify that I/We have read, understood, and unconditionally accept all the terms and conditions of the tender documents, including all sections, schedules, annexures, and corrigenda issued from time to time, which shall form an integral part of the Contract Agreement. I/We agree to abide by all the terms, conditions, and provisions contained therein.

(c) I/We declare that neither the Government of India nor any State Government / Public Sector Undertaking / Autonomous Body has blacklisted, debarred, or declared us ineligible on grounds of corrupt, fraudulent, collusive, or coercive practices, or for any serious lapses.

(d) I/We certify that all statements, documents, and information submitted by us are true and correct. I/We agree that our bid shall remain valid for a period of ninety (90) days from the date of opening of the Financial Bid and shall remain binding upon us and may be accepted at any time prior to the expiry of the said period.

(e) If our bid is accepted, I/We undertake to execute the Contract Agreement and submit the Performance Guarantee / Security within the stipulated time and in accordance with the provisions of the tender documents.

(f) I/We acknowledge that **NERAMAC** is not bound to accept the lowest bid or any other bid and that the Financial Bid shall not be opened if I/We are found technically unqualified during evaluation.

(g) I/We submit the requisite Solvency Certificate and hereby authorise **NERAMAC** or its authorised representative to approach the concerned bank(s) for verification of the same. I/We further authorise **NERAMAC** to verify our credentials, experience, and general reputation from individuals, firms, or organisations, as deemed necessary.

Yours faithfully,

Signature of Authorised Signatory

Name (in full):

Designation:

Name of Bidder/Firm/Company:

Address:

Contact No.:

Email ID:

*(Authorised signatory shall attach a copy of valid authorisation / Power of Attorney for signing on behalf of the bidder.)*

[To be submitted as part of the Technical Bid]

[On Bidder's / Company Letterhead]  
[Along with supporting documents]

## FORM – II

### POWER OF ATTORNEY

KNOW ALL MEN BY THESE PRESENTS that we, \_\_\_\_\_, a company / firm / LLP incorporated under the laws of India and having its registered office at \_\_\_\_\_ (hereinafter referred to as the "Principal"), do hereby nominate, constitute and appoint Mr./Ms. \_\_\_\_\_, as our true and lawful Attorney (hereinafter referred to as the "Attorney") to do the following acts, deeds and things on our behalf:

(1) To sign, submit, modify, withdraw and re-submit our bid, technical and financial documents, schedules, annexures, clarifications, and all other documents in connection with the tender invited by **North Eastern Regional Agricultural Marketing Corporation Ltd. (NERAMAC)**.

(2) To represent us in all matters relating to the above tender, including attending meetings, negotiations (if any), presentations, and communications with **NERAMAC** or its authorised representatives.

(3) To receive, acknowledge, and act upon all communications, notices, corrigenda, addenda, Letters of Acceptance, and instructions issued by **NERAMAC** in connection with the tender.

(4) In the event of award of work, to sign the Letter of Acceptance, Agreement, Contract documents, and any other documents required for execution of the work, and to submit Performance Guarantee and other securities as required under the tender conditions.

(5) To do all such acts, deeds, and things as may be necessary, proper, or expedient for the purpose of participating in and securing the above tender and execution of the contract.

We hereby agree that all acts, deeds, and things lawfully done by the said Attorney pursuant to this Power of Attorney shall be binding on us as if the same had been done by us personally.

This Power of Attorney shall remain valid until completion of the tender process and execution of the contract, unless revoked earlier in writing.

**IN WITNESS WHEREOF**, we have executed this Power of Attorney on this \_\_\_\_\_ day of \_\_\_\_\_ 20\_\_\_\_.

**For and on behalf of:**

(Name of the Company / Firm)

Signature: \_\_\_\_\_  
Name: \_\_\_\_\_  
Designation: \_\_\_\_\_

**Witnesses**

1. \_\_\_\_\_
2. \_\_\_\_\_

[To be submitted as part of the Technical Bid]

[On Bidder's / Company Letterhead]  
[Along with supporting documents]

### FORM – III

#### BIDDER INFORMATION

**Bidder's Name:** \_\_\_\_\_  
[Address and Contact Details]

**Bidder's Reference No.:** \_\_\_\_\_

**Date:** \_\_\_\_\_

**Tender Document No.:**NER/AGRIBUSINESS/AGAR-CD/584

**Tender Title:** Construction of Agarwood Cluster processing unit at Golaghat, Assam and Kadamtala Tripura

(Note: The Bidder shall fill in this Form strictly in accordance with the instructions given herein. No alterations to this Form shall be permitted and no substitutions shall be accepted. The Bidder shall enclose self-certified copies of documentary proof / evidence to substantiate the corresponding statements wherever applicable. Any wrong or misleading information shall be treated as a violation of the Code of Integrity and may result in rejection of the bid as non-responsive, in addition to other punitive actions as provided in the Tender Document.)

#### (1) Bidder / Contractor Particulars

(a) Name of Individual / Contractor / Company: \_\_\_\_\_

(b) Corporate Identity Number (CIN) (if applicable): \_\_\_\_\_

(c) Place of Registration / Principal Place of Business: \_\_\_\_\_

(d) Complete Postal Address: \_\_\_\_\_

(e) PIN / ZIP Code: \_\_\_\_\_

(f) Telephone No.: \_\_\_\_\_

(g) Mobile No.: \_\_\_\_\_

(h) Contact Person(s) & Designation: \_\_\_\_\_

(i) Email ID(s): \_\_\_\_\_

**(2) Taxation Registrations**

(a) PAN Number: \_\_\_\_\_

(b) Type of GST Registration as per the Act: \_\_\_\_\_

(c) GSTIN Number: \_\_\_\_\_

(d) Registered / Certified Works Manufactured / Place of Consignor (for GST purpose):  
\_\_\_\_\_

(e) Contact Names, Nos. & Email IDs for GST matters (Please mention primary and secondary contacts): \_\_\_\_\_

I/We solemnly declare that our GST rating on the GST portal / Government official website is not negative or blacklisted.

**Documents to be submitted:**

- (i) Self-attested copy of PAN Card
- (ii) Self-attested copy of GST Registration Certificate

**(3) Authorization of Person(s) Signing the Bid on behalf of the Bidder**

(a) Full Name: \_\_\_\_\_

(b) Designation: \_\_\_\_\_

(c) Signing as:

Proprietor Firm (The person signing is duly authorized)

Company (The person signing is authorized by Board Resolution / Memorandum of Association)

**Documents to be enclosed:**

- (i) Registration Certificate

**(4) Bidder's Authorized Representative Details**

(a) Name: \_\_\_\_\_

(b) Address: \_\_\_\_\_

(c) Telephone / Mobile No.: \_\_\_\_\_

(d) Email Address: \_\_\_\_\_

**Signature of Authorized Person(s)**  
**Authorised Signatory**

*(Authorized person should attach a copy of authorization for signing on behalf of bidding company)*

**Date:** \_\_\_\_\_

**Full Name:** \_\_\_\_\_

**Place:** \_\_\_\_\_

**Seal:** \_\_\_\_\_

[To be submitted as part of the Technical Bid]

[On Bidder's / Company Letterhead]  
[Along with supporting documents]

**FORM – IV**

**ELIGIBILITY DECLARATIONS**

**Bidder's Name:** \_\_\_\_\_  
[Address and Contact Details]

**Bidder's Reference No.:** \_\_\_\_\_  
**Date:** \_\_\_\_\_

**Tender Document No.:**NER/AGRIBUSINESS/AGAR-CD/584

**Tender Title:**Construction of Agarwood Cluster processing unit at Golaghat, Assam and Kadamtala Tripura

(Note: The list of declarations below is indicative. The Bidder may attach additional documents, wherever required, to substantiate compliance with eligibility criteria as prescribed in the Tender Document.)

**Eligibility Declarations**

I / We hereby confirm that I / We comply with all eligibility requirements and conditions stipulated in the tender document and hereby declare accordingly. I / We further undertake to provide evidence of continued eligibility to **NERAMAC**, as and when required.

**(1) Legal Entity of the Bidder / Legal Name of the Bidder / Contractor:**

\_\_\_\_\_  
\_\_\_\_\_

**(2) Declaration**

I / We solemnly declare that I / We (including our affiliates, subsidiaries, constituents, contractors, and subcontractors):

(a) Are not insolvent, bankrupt, under receivership, being wound up, or subject to any court or judicial administration; our business activities are not suspended and we are not under any legal proceedings for such reasons.

(b) Do not stand declared ineligible, blacklisted, banned, suspended, or debarred by any Procuring Entity or its Ministry / Department.

(c) Have not been convicted, nor declared ineligible, suspended, blacklisted, banned, or debarred by any authority of the Government of India within the last three (3) years preceding the last date of bid submission.

(d) We confirm that we have neither changed our name nor created any allied firm to circumvent such disqualification.

(e) Do not have any association, whether as bidder, partner, director, or employee, with any retired public official or close relative of such official of **NERAMAC**, where such association is prohibited under the Tender Document.

(f) Fulfil all additional eligibility conditions, if any, prescribed in the Tender Document.

(g) Have no conflict of interest that may adversely affect fair competition. Prices quoted are competitive and free from any unfair, unethical, or anti-competitive practices.

### **(3) MSME Status**

I / We shall abide by the compliance of Public Procurement (Preference to Make in India) Order, 2017 and subsequent amendments from time to time, and declare that:

(a) The bidder is compliant with Public Procurement (Preference to Make in India) Order, 2017 and subsequent amendments dated 16th September 2020, as relevant and applicable.

(b) The bidder is compliant with the provisions of Rule 144(xi) of GFR 2017.

Having read and understood the Public Procurement Policy for Micro and Small Enterprises (MSEs) Order, 2012 (as amended and revised till date), I / We solemnly declare the following:

- (a) I / We are: Micro / Small / Medium Enterprise / SSI / Govt. Deptt. / PSU / Others:  
\_\_\_\_\_
- (b) We attach herewith Udhyam Registration Certificate with the Udhyam Registration Number as proof of our being MSE registered on the Udhyam Registration Portal. The certificate is valid up to the deadline for submission of the bid.
- (c) Whether Proprietor belongs to SC / ST or Women category:  
\_\_\_\_\_

### **(4) Declaration on False or Misleading Information**

I / We confirm that the information furnished above is true, complete, and correct. Nothing material has been concealed. I / We understand that any false or misleading declaration shall be treated as a violation of the Code of Integrity and shall attract penalties as provided in the Tender Document.

### **(5) Self-Declaration**

I / We hereby further declare that:

(a) I / We have carefully read and understood all the terms and conditions of the Tender and agree to abide by them.

(b) My / Our firm has not been blacklisted or debarred by any Ministry / Department of Government of India in the last three (3) years as on the date of opening of the tender.

(c) I / We have inspected the work site and am / are fully aware of the nature, quality, and quantity of work involved.

(d) I / We understand that submission of any false information or fabricated document shall result in rejection of the bid and may lead to prosecution under applicable law.

(e) I / We agree that the Competent Authority of **NERAMAC** shall have the right to forfeit Earnest Money / Security Deposit in case of breach of contract conditions.

(f) My / Our bid is unconditional and free from any qualifications or deviations.

(g) All documents submitted along with the bid are genuine and authentic to the best of my / our knowledge and belief.

**Signature of Authorized Person(s)**

**Authorised Signatory**

*(Authorized person should attach a copy of authorization for signing on behalf of bidding company)*

**Date:** \_\_\_\_\_

**Full Name:** \_\_\_\_\_

**Place:** \_\_\_\_\_

**Seal:** \_\_\_\_\_

[To be submitted as part of the Technical Bid]

[On Bidder's / Company Letterhead]

## FORM – V

### QUALIFICATION CRITERIA – COMPLIANCE

**Bidder's Name:** \_\_\_\_\_  
[Address and Contact Details]

**Tender Document No.:**NER/AGRIBUSINESS/AGAR-CD/584

**Tender Title:** Construction of Agarwood Cluster Processing Unit at Golaghat, Assam and Kadamtala, Tripura

(Note to Bidders: Furnish statements and documents to confirm conformity to Qualification Criteria as mentioned/attached here. You may attach more documents as required for qualification criteria. Add additional details not covered elsewhere in your bid in this regard. Non-submission or incomplete submission of documents may lead to rejection of the bid as non-responsive.)

#### Documents Attached Supporting the Compliance to Qualification Criteria

Sl. No.	Requirement	Copy of Relevant Document to be Attached (Duly Filled, Signed & Self-Attested)	Yes / No	Page No.
1	Contractors / firms registration with appropriate registration authority (CPWD / PWD / MES / Public Works and any other local bodies)	Copy of Valid Registration Certificate / Enlistment Certificate		
2	Earnest Money Deposit (EMD)	Copy of DD / NEFT Payment Proof OR MSEs with NSIC Certificate / Bid Security Declaration (Form No. VII)		
3	GST Registration	Copy of Valid GST Registration Certificate (also attach GST returns / challan for last quarter of FY 2024–25)		
4	PAN card in the name of company / firm / agency / bidder	Copy of PAN Card		
5	Turnover Requirement	Copy of Turnover Certificate and CA audited statements for FY 2022–23, 2023–24 & 2024–25 (Annexure–III). Average Annual Turnover should be at least ₹300 Lakhs of estimated amount		
6	Income Tax Returns	Copies of Income Tax Returns for last		

		three financial years (AY 2023–24, 2024–25 & 2025–26)		
7	Work Experience	Copy of Work Orders / Completion Certificates / Client Certificates for similar works during last seven years (April 2020 till date of tender publication), indicating work value & duration		

**Work Experience Criteria (Any one of the following):**

Criteria	Requirement	Yes / No
(a)	Three similar completed works costing not less than ₹280 Lakhs each	
(b)	Two similar completed works costing not less than ₹420 Lakhs each	
(c)	One similar completed work costing not less than ₹560 Lakhs	

**Definition of Similar Work:**

Any kind of building construction works or repair, renovation, and maintenance works related to:

- Worksheds
- Workshops
- Educational buildings
- Institutional buildings
- Public buildings
- Government residential quarters

**Signature of Authorized Person(s)  
Authorised Signatory**

*(Authorized person should attach a copy of authorization for signing on behalf of bidding company)*

**Date:** \_\_\_\_\_

**Full Name:** \_\_\_\_\_

**Place:** \_\_\_\_\_

**Seal:** \_\_\_\_\_

[To be submitted as part of the Technical Bid]

[On Bidder's / Company Letterhead]

## FORM – VI

### PERFORMANCE STATEMENT

**Bidder's Name:** \_\_\_\_\_

[Address and Contact Details]

**Bidder's Reference No.:** \_\_\_\_\_

**Date:** \_\_\_\_\_

**Tender Document No.:**NER/AGRIBUSINESS/AGAR-CD/584

**Tender Title:**Construction of Agarwood Cluster Processing Unit at Golaghat, Assam and Kadamtala, Tripura

(Note to Bidders: Fill up this Form for your past performance highlighting your qualifications for execution of relevant works. Statements and documents to the Performance Statement may be mentioned/attached here. The list below is indicative only. You may attach more documents as required to showcase your past performance. Add additional details not covered elsewhere in your bid in this regard.)

#### Performance Details

Work Order Issued By	Work Order No. & Date	Value of the Order	Work Done Certificate Issued By	Work Done Certificate No. & Date	Value of Work Done
----------------------	-----------------------	--------------------	---------------------------------	----------------------------------	--------------------

**Signature of Authorized Person(s)**

**Authorised Signatory**

*(Authorized person should attach a copy of authorization for signing on behalf of bidding company)*

**Date:** \_\_\_\_\_

**Full Name:** \_\_\_\_\_

**Place:** \_\_\_\_\_

**Seal:** \_\_\_\_\_

[To be submitted as part of the Technical Bid]

[On Bidder's / Company Letterhead]

## FORM – VII

### DOCUMENTS RELATING TO BID SECURITY

(Note: To be submitted as part of Technical Bid, along with supporting documents, if any. Submit as Form VII as part of Technical Bid, a Bid Securing Declaration in lieu of bid security in the following format. Bidders exempted from submission of bid security are also required to submit this.)

#### BID SECURING DECLARATION

**Bidder's Name:** \_\_\_\_\_

[Address and Contact Details]

**Bidder's Reference No.:** \_\_\_\_\_

**Date:** \_\_\_\_\_

To,  
The Managing Director,  
**North Eastern Regional Agricultural Marketing Corporation Ltd. (NERAMAC)**  
NERAMAC Complex, Six Mile,  
Near Panjabari Flyover,  
Guwahati – 781022

**Tender Document No.:**NER/AGRIBUSINESS/AGAR-CD/584

**Tender Title:**Construction of Agarwood Cluster Processing Unit at Golaghat, Assam and Kadamtala, Tripura

**Sir / Madam,**

- (1) I / We hereby submit the following declaration in lieu of submitting Earnest Money Deposit.
- (2) That I / We have availed the benefit of waiver of EMD while submitting our offer against the subject tender and no EMD is being deposited for the said tender.
- (3) If, after opening of tender, I / We withdraw or modify my / our bid during the period of validity of tender (including extended validity of tender) specified in the tender documents,
- (4) If, after award of the work, I / We fail to sign the contract or to submit Performance Guarantee before the deadline defined in the tender documents, or I / We commit any breach of tender conditions / contract which attracts penal action of forfeiture of EMD,

(5) I / We shall be suspended for one year and shall not be eligible to bid for NERAMAC tenders from the date of issue of suspension order.

(6) We understand that this Bid-Securing Declaration shall expire if the contract is not awarded to us, upon:

- (a) Receipt by us of your notification:
  - (i) of cancellation of the entire tender process or rejection of all bids; or
  - (ii) of the name of the successful bidder;

**OR**

- (b) Forty-five (45) days after the expiration of the bid validity or any extension to it.

**Signature of Authorized Person(s)**

**Authorised Signatory**

*(Authorized person should attach a copy of authorization for signing on behalf of bidding company)*

**Date:** \_\_\_\_\_

**Full Name:** \_\_\_\_\_

**Place:** \_\_\_\_\_

**Seal:** \_\_\_\_\_

## FORM – VIII

### INTEGRITY PACT (PROCURING ENTITY FORM)

[To be submitted as part of the Technical Bid]  
[On Bidder's / Company Letterhead]

To,

M/s \_\_\_\_\_

---

---

---

**Tender Document No.:NER/AGRIBUSINESS/AGAR-CD/584**

**Tender Title:** Construction of Agarwood Cluster Processing Unit at Golaghat, Assam and Kadamtala, Tripura

Dear Sir,

It is hereby declared that **North Eastern Regional Agricultural Marketing Corporation Ltd. (NERAMAC)** is committed to upholding the principles of transparency, equity, and competitiveness in public procurement.

The subject Notice Inviting Tender (NIT) is issued with the condition that the bidder shall sign the Integrity Agreement, which forms an integral part of the tender / bid documents. Failure to sign the Integrity Agreement shall render the bidder disqualified from the tendering process, and the bid submitted by such bidder shall be summarily rejected.

This declaration shall form part and parcel of the Integrity Agreement, and signing of this declaration shall be deemed to be acceptance of, and agreement to, the Integrity Agreement on behalf of the bidder with **NERAMAC**.

Yours faithfully,

**Managing Director**

North Eastern Regional Agricultural Marketing Corporation Ltd. (NERAMAC)

## Form-IX

### INTEGRITY PACT (BIDDER'S FORM)

[To be submitted as part of the Technical Bid]  
[On Bidder's / Company Letterhead]

To,  
The Managing Director,  
**North Eastern Regional Agricultural Marketing Corporation Ltd. (NERAMAC)**  
NERAMAC Complex, Six Mile,  
Near Panjabari Flyover,  
Guwahati – 781022

**Sub:** Submission of Tender for the Work

**Tender No.:**NER/AGRIBUSINESS/AGAR-CD/584

**Tender Title:** Construction of Agarwood Cluster Processing Unit at Golaghat, Assam and Kadamtala, Tripura

Dear Sir,

I / We acknowledge that **NERAMAC** is committed to follow the principles thereof as enumerated in the Integrity Agreement enclosed with the tender / bid document.

I / We agree that the Notice Inviting Tender (NIT) is an invitation to offer made on the condition that I / We will sign the enclosed Integrity Agreement, which is an integral part of the tender documents, failing which I / We will stand disqualified from the tendering process.

I / We acknowledge that the making of the bid shall be regarded as an unconditional and absolute acceptance of this condition of the NIT.

I / We confirm acceptance and compliance with the Integrity Agreement in letter and spirit and further agree that execution of the said Integrity Agreement shall be separate and distinct from the main contract, which shall come into existence when the tender / bid is finally accepted by **NERAMAC**.

I / We acknowledge and accept the duration of the Integrity Agreement, which shall be in line with Article 1 of the enclosed Integrity Agreement.

I / We acknowledge that, in the event of my / our failure to sign and accept the Integrity Agreement while submitting the tender / bid, **NERAMAC** shall have the unqualified, absolute, and unfettered right to disqualify the tenderer / bidder and reject the tender / bid in accordance with the terms and conditions of the tender / bid.

Yours faithfully,

**Signature of Authorized Person(s)**  
**Authorised Signatory**

*(Authorized person should attach a copy of authorization for signing on behalf of bidding company)*

---

**Date:** \_\_\_\_\_

**Full Name:** \_\_\_\_\_

**Place:** \_\_\_\_\_

**Seal:** \_\_\_\_\_

*To be signed by the bidder and same signatory competent / authorized to sign the relevant contract on behalf of NERAMAC.*

## INTEGRITY AGREEMENT

This Integrity Agreement is made at **Guwahati** on this \_\_\_\_\_ day of \_\_\_\_\_ 2025

### BETWEEN

Managing Director, North Eastern Regional Agricultural Marketing Corporation Ltd (NERAMAC), **NERAMAC Complex, Six Mile, Panjabari Flyover, Guwahati, Assam – 781022** (Hereinafter referred to as the “Principal / Owner”, which expression shall, unless repugnant to the meaning or context hereof, include its successors and permitted assigns)

### AND

(Name and address of the Individual / Firm / Company) through (Details of duly authorized signatory)

(hereinafter referred to as the “Bidder / Contractor”, which expression shall, unless repugnant to the meaning or context hereof, include its successors and permitted assigns)

### PREAMBLE

WHEREAS the Principal / Owner has floated the Tender, **Tender Document No. NER/AGRIBUSINESS/AGAR-CD/584** (hereinafter referred to as the “Tender/Bid”) and intends to award, under laid-down organizational procedure, a contract for the work titled: **Construction of Agarwood Cluster Processing Unit at Golaghat, Assam and Kadamtala, Tripura** (hereinafter referred to as the “Contract”).

AND WHEREAS the Principal / Owner values full compliance with all relevant laws of the land, rules, regulations, economic use of resources, and fairness and transparency in its relations with its Bidders and Contractors.

AND WHEREAS to meet the purpose aforesaid, both the parties have agreed to enter into this Integrity Agreement (hereinafter referred to as the “Integrity Pact” or “Pact”), the terms and conditions of which shall be read as an integral part and parcel of the Tender / Bid documents and Contract between the parties.

NOW THEREFORE, in consideration of mutual covenants contained in this Pact, the parties hereby agree as follows and this Pact witnesses as under:

#### **Article 1: Commitment of the Principal / Owner**

(1) The Principal / Owner commits itself to take all measures necessary to prevent corruption and to observe the following principles:

(a) No employee of the Principal / Owner, personally or through any of his / her family members, shall, in connection with the Tender or execution of the Contract, demand, take a promise for, or accept, for self or for a third person, any material or immaterial benefit which the person is not legally entitled to.

(b) The Principal / Owner shall, during the Tender process, treat all Bidders with equity and reason. The Principal / Owner shall, in particular, before and during the Tender process, provide to all Bidders the same information and shall not provide to any Bidder confidential or additional information through which the Bidder(s) could obtain an advantage in relation to the Tender process or Contract execution.

(c) The Principal / Owner shall endeavour to exclude from the Tender process any person whose conduct in the past has been of biased nature.

(2) If the Principal / Owner obtains information on the conduct of any of its employees which is a criminal offence under the Indian Penal Code (IPC) / Prevention of Corruption Act, 1988 (PC Act), or is in violation of the principles herein mentioned, or if there is a substantive suspicion in this regard, the Principal / Owner shall inform the Chief Vigilance Officer and, in addition, can also initiate disciplinary actions as per its internal laid-down policies and procedures.

## **Article 2: Commitment of the Bidder(s) / Contractor(s)**

(1) It is required that each Bidder / Contractor (including their respective officers, employees, and agents) adhere to the highest ethical standards and report to the Government / Department all suspected acts of fraud, corruption, coercion, or collusion of which it has knowledge or becomes aware, during the tendering process and throughout the negotiation or award of a contract.

(2) The Bidder(s) / Contractor(s) commits himself to take all measures necessary to prevent corruption and commits himself to observe the following principles during participation in the Tender process and during Contract execution:

(a) The Bidder(s) / Contractor(s) shall not, directly or through any other person or firm, offer, promise, or give to any of the Principal / Owner's employees involved in the Tender process or execution of the Contract, or to any third person, any material or other benefit which he / she is not legally entitled to, in order to obtain in exchange any advantage of any kind whatsoever during the Tender process or execution of the Contract.

(b) The Bidder(s) / Contractor(s) shall not enter into any undisclosed agreement or understanding with other Bidders, whether formal or informal. This applies in particular to prices, specifications, certifications, subsidiary contracts, submission or non-submission of bids, or any other actions to restrict competitiveness or cartelize in the bidding process.

(c) The Bidder(s) / Contractor(s) shall not commit any offence under the relevant IPC / PC Act. Further, the Bidder(s) / Contractor(s) shall not use improperly, for the purpose of competition or personal gain, or pass on to others, any information or documents provided by the Principal / Owner as part of the business relationship, regarding plans, technical proposals, business details, including information contained or transmitted electronically.

(d) The Bidder(s) / Contractor(s) of foreign origin shall disclose the names and addresses of agents / representatives in India, if any. Similarly, Bidder(s) / Contractor(s) of Indian nationality shall disclose names and addresses of foreign agents / representatives, if any. Either the Indian agent on behalf of the foreign principal or the foreign principal directly may bid in a tender, but not both. Further, where an agent participates in a tender on behalf of one

manufacturer, he shall not be allowed to quote on behalf of another manufacturer along with the first manufacturer in a subsequent or parallel tender for the same item.

(e) The Bidder(s) / Contractor(s) shall, when presenting the bid, disclose any and all payments he has made, is committed to, or intends to make to agents, brokers, or any other intermediaries in connection with the award of the Contract.

(3) The Bidder(s) / Contractor(s) shall not instigate third persons to commit offences outlined above or be an accessory to such offences.

(4) The Bidder(s) / Contractor(s) shall not, directly or through any other person or firm, indulge in fraudulent practice, including misrepresentation or omission of facts or submission of fake/forged documents, in order to induce a public official to act in reliance thereof, with the purpose of obtaining unjust advantage or causing damage to justified interest of others and / or to influence the procurement process to the detriment of Government interests.

(5) The Bidder(s) / Contractor(s) shall not, directly or through any other person or firm, use coercive practices (meaning the act of obtaining something, compelling an action, or influencing a decision through intimidation, threat, or use of force, directly or indirectly), where potential or actual injury may befall upon a person, his / her reputation, or property to influence participation in the tendering process.

### **Article 3: Consequences of Breach**

Without prejudice to any rights that may be available to the Principal / Owner under law or the Contract or its established policies and laid-down procedures, the Principal / Owner shall have the following rights in case of breach of this Integrity Pact by the Bidder(s) / Contractor(s), and the Bidder / Contractor accepts and undertakes to respect and uphold the Principal / Owner's absolute right:

(1) If the Bidder(s) / Contractor(s), either before award or during execution of the Contract, has committed a transgression through a violation of Article 2 above or in any other form, such as to put his reliability or credibility in question, the Principal / Owner, after giving 14 days' notice to the Contractor, shall have the power to disqualify the Bidder(s) / Contractor(s) from the Tender process or terminate / determine the Contract, if already executed, or exclude the Bidder / Contractor from future contract award processes. The imposition and duration of such exclusion shall be determined by the severity of the transgression and decided by the Principal / Owner. Such exclusion may be forever or for a limited period.

(2) **Forfeiture of EMD / Performance Guarantee / Security Deposit:** If the Principal / Owner has disqualified the Bidder(s) from the Tender process prior to award of the Contract or has terminated / determined the Contract or has accrued the right to terminate / determine the Contract in accordance with Article 3(1), the Principal / Owner may, after exercising any legal rights that may have accrued, in its considered opinion, forfeit the entire amount of Earnest Money Deposit, Performance Guarantee, and Security Deposit of the Bidder / Contractor.

(3) **Criminal Liability:** If the Principal / Owner obtains knowledge of conduct of a Bidder or Contractor, or of an employee, representative, or associate of a Bidder or Contractor, which constitutes corruption within the meaning of the IPC / PC Act, or if the Principal / Owner has

substantive suspicion in this regard, the Principal / Owner shall inform the same to the law-enforcing agencies for further investigation.

#### **Article 4: Previous Transgression**

(1) The Bidder declares that no previous transgressions occurred in the last five (5) years with any other company in any country conforming to the anti-corruption approach or with the Central Government or State Government or any other Central / State Public Sector Enterprises in India that could justify its exclusion from the Tender process.

(2) If the Bidder makes an incorrect statement on this subject, the Bidder can be disqualified from the Tender process, or action can be taken for banning of business dealings / holiday listing of the Bidder / Contractor, as deemed fit by the Principal / Owner.

(3) If the Bidder / Contractor can prove that he has resorted to / recouped the damage caused by him and has installed a suitable corruption-prevention system, the Principal / Owner may, at its own discretion, revoke the exclusion prematurely.

#### **Article 5: Equal Treatment of all Bidders / Contractors / Sub-contractors**

(1) The Bidder(s) / Contractor(s) undertake(s) to demand from all subcontractors a commitment in conformity with this Integrity Pact. The Bidder / Contractor shall be responsible for any violation(s) of the principles laid down in this Integrity Pact by any of its subcontractors / sub-vendors.

(2) The Principal / Owner will enter into Integrity Pacts on identical terms as this one with all Bidders and Contractors.

#### **Article 6: Duration of the Pact**

This Pact begins when both the parties have legally signed it. It expires for the Contractor / Vendor 12 months after the completion of work under the Contract or till the continuation of defect liability period, whichever is more, and for all other bidders, till the Contract has been awarded.

If any claim is made / lodged during this period, the same shall be binding and continue to be valid despite the lapse of this Pact, as specified above, unless it is discharged / determined by the Competent Authority, NERAMAC.

#### **Article 7: Other Provisions**

(1) This Pact is subject to Indian Law. Place of performance and jurisdiction shall be the Headquarters of the Division of the Principal / Owner who has floated the Tender.

(2) Changes and supplements need to be made in writing. Side agreements shall not be made.

(3) Should one or several provisions of this Pact turn out to be invalid, the remainder of this Pact shall remain valid. In this case, the parties shall strive to come to an agreement to their original intentions.

(4) It is agreed as a term and condition that any dispute or difference arising between the parties with regard to the terms of this Integrity Agreement / Pact, any action taken by the Owner / Principal in accordance with this Integrity Agreement / Pact, or interpretation thereof, shall not be subject to arbitration.

**Article 8: Legal and Prior Rights**

All rights and remedies of the parties hereto shall be in addition to all other legal rights and remedies belonging to such parties under the Contract and / or law, and the same shall be deemed to be cumulative and not alternative to such legal rights and remedies aforesaid.

For the sake of brevity, both the Parties agree that this Integrity Pact shall have precedence over the Tender / Contract documents with regard to the provisions covered under this Integrity Pact.

**IN WITNESSES WHEREOF**, the parties have signed this agreement at Guwahati on the date first mentioned above in presence of witnesses.

**For** (Name and address of Bidder / Contractor)

**Signature** (Name & Designation of Authorized Signatory) (With Company Seal)

**For** North Eastern Regional Agricultural Marketing Corporation (NERAMAC)

**Managing Director** North Eastern Regional Agricultural Marketing Corporation Ltd (NERAMAC) NERAMAC Complex, Six Mile, Panjabari Flyover, Guwahati, Assam – 781022

**Witnesses**

- |                    |                    |
|--------------------|--------------------|
| 1. _____           | 1. _____           |
| (Name & Signature) | (Name & Signature) |
| 2. _____           | 2. _____           |
| (Name & Signature) | (Name & Signature) |

**[To be submitted as part of the Technical Bid]**

**[On Bidder's / Company Letterhead]**

**FORM – X**

**TENDER ACCEPTANCE LETTER**

To,  
The Managing Director,  
**North Eastern Regional Agricultural Marketing Corporation Ltd. (NERAMAC)**  
NERAMAC Complex, Six Mile,  
Near Panjabari Flyover,  
Guwahati – 781022

**Sub:** Submission of Tender for the Work

**Tender No.:**NER/AGRIBUSINESS/AGAR-CD/584

**Tender Title:** Construction of Agarwood Cluster Processing Unit at Golaghat, Assam and Kadamtala, Tripura

Dear Sir,

(1) I / We have downloaded / obtained the tender document(s) for the above-mentioned tender / work from the website(s) as per your advertisement given in the above-mentioned website(s).

(2) I / We hereby certify that I / We have read the entire terms and conditions of the tender documents (including all documents like Annexure(s), Schedule(s), etc., which form part of the Contract Agreement) and I / We shall abide hereby with the terms / conditions / clauses contained therein.

(3) The corrigendum(s) issued from time to time by your Department / Organization have also been taken into consideration while submitting this Tender Acceptance Letter.

(4) I / We do hereby declare that our firm has not been blacklisted / debarred by any Government Department / Public Sector Undertaking.

(5) I / We certify that all information furnished by our firm is true and correct. In the event that the information is found to be incorrect / untrue or found violated, then your Department / Organization shall, without giving any notice or reason thereof, be at liberty to summarily reject the bid or terminate the contract, without prejudice to any other rights or remedies including forfeiture of the said Earnest Money Deposit in full absolutely.

Yours faithfully,

**Signature of Authorized Person(s)**  
**Authorised Signatory**

*(Authorized person should attach a copy of authorization for signing on behalf of bidding company)*

**Date:** \_\_\_\_\_

**Full Name:** \_\_\_\_\_

**Place:** \_\_\_\_\_

**Seal:** \_\_\_\_\_

**[To be submitted as part of the Technical Bid]**

**[On Bidder's / Company Letterhead]**

**FORM – XI**

**SITE VISIT DECLARATION**

**Tender Document No.:NER/AGRIBUSINESS/AGAR-CD/584**

**Tender Title:** Construction of Agarwood Cluster Processing Unit at Golaghat, Assam and Kadamtala, Tripura

Dear Sir,

I / We, \_\_\_\_\_ (Name of the Tenderer / Authorized Representative), hereby declare that I / We have visited the project site at \_\_\_\_\_ on \_\_\_\_\_ (date).

During the site visit, I / We have collected all necessary information and data relevant to the work, including availability of materials, site conditions, access, logistics, and environmental conditions. I / We fully understand the scope of work and confirm that the bid has been prepared after due consideration of all site-specific conditions.

I / We further confirm that no claim on account of lack of site knowledge shall be entertained at a later stage.

**Encl.:** GPS tagged image(s) of the site

Yours faithfully,

**Signature of Authorized Person(s)**  
**Authorised Signatory**

**[To be submitted as part of the Technical Bid]**

**[On Letterhead of the Bank]**

**FORM – XII**

**FORM OF BANKER'S CERTIFICATE FROM A NATIONALISED BANK**

This is to certify that to the best of our knowledge and information that M/s / Shri  
\_\_\_\_\_ (with address) is / are customer(s) of our bank and is / are  
respectable and can be treated as good for any engagement up to a limit of ₹  
\_\_\_\_\_ (Rupees \_\_\_\_\_ only).

This certificate is issued without any guarantee or responsibility on the bank or any of its officers.

**Signature**

Name of the Bank & Branch with Seal

[To be submitted as part of the Technical Bid]

[On Bidder's / Company Letterhead]

## FORM – XIII

### CHECKLIST FOR BIDDERS

**Bidder's Name:** \_\_\_\_\_  
[Address and Contact Details]

**Bidder's Reference No.:** \_\_\_\_\_

**Date:** \_\_\_\_\_

**Tender Document No.:**NER/AGRIBUSINESS/AGAR-CD/584

**Tender Title:** Construction of Agarwood Cluster Processing Unit at Golaghat, Assam and Kadamtala, Tripura

#### Checklist

Sl. No.	Documents Submitted (Duly Filled, Signed)	Yes / No / NA
1	Form I: Bid Submission / Acceptance Letter	
2	Form II: Power of Attorney	
3	Form III: Bidder Information	
4	Form IV: Eligibility Declarations	
5	Form V: Qualification Criteria – Compliance	
6	Form VI: Performance Statement	
7	Form VII: Documents relating to Bid Security	
8	Form VIII: Integrity Pact (Procuring Entity Form)	
9	Form IX: Integrity Pact (Bidder's Form)	
10	Form X: Tender Acceptance Letter	
11	Form XI: Site Visit Declaration	
12	Form XII: Banker's Certificate	
13	Price Bid – duly filled on e-portal and uploaded	
14	Head Office / Branch Office in North East (Affidavit)	

**Signature of Authorized Person(s)**  
**Authorised Signatory**

*(Authorized person should attach a copy of authorization for signing on behalf of bidding company)*

**Date:** \_\_\_\_\_

**Full Name:** \_\_\_\_\_

**Place:** \_\_\_\_\_

**Seal:** \_\_\_\_\_

**ANNEXURE – I**  
**CONTRACT FORM**

To,  
The Managing Director,  
**North Eastern Regional Agricultural Marketing Corporation Ltd. (NERAMAC)**  
NERAMAC Complex, Six Mile,  
Near Panjabari Flyover,  
Guwahati – 781022

**Contract No.:** \_\_\_\_\_

**Dated:** \_\_\_\_\_

To,  
**Contractor:** \_\_\_\_\_  
[Complete Address of the Contractor]

**Subject:** \_\_\_\_\_

**Ref:**

1. This office Letter of Award (LoA) No. \_\_\_\_\_ dated \_\_\_\_\_
2. This office Tender Document No. **NER/AGRIBUSINESS/AGAR-CD/584**;  
Tender Title: *Construction of Agarwood Cluster Processing Unit at Golaghat, Assam and Kadamtala, Tripura*, dated \_\_\_\_\_ and subsequent Amendment No. \_\_\_\_\_ dated \_\_\_\_\_ (if any)  
(Hereinafter referred to as “the Tender Document”)
3. Your Tender No. \_\_\_\_\_ dated \_\_\_\_\_ and subsequent communication(s) / Revised Offer No. \_\_\_\_\_ dated \_\_\_\_\_ (if any), exchanged between you and this office in connection with this tender  
(Hereinafter referred to as “Your Offer”)

Dear Sir / Madam,

Your bid referred above, read with subsequent letters mentioned above, for the works stipulated in the schedules annexed herewith, has been accepted. Terms and conditions in this Contract and the documents listed in the clause below shall apply.

2. Terms and conditions in the documents mentioned under Reference No. 1, 2, and 3 above (including General Conditions of Contract) shall also be part of this Contract.

*(Note: The words, expressions, definitions, and abbreviations used in this Contract shall have the same meanings as are respectively assigned to them in the General Conditions of Contract of the Tender Document.)*

**(Signature, Name & Address of Procuring Entity’s Authorized Official)**  
For and on behalf of **NERAMAC**

**Received and accepted this Contract**

(Signature, Name & Address of Contractor's Authorized Signatory)  
For and on behalf of \_\_\_\_\_

**Seal of the Contractor**

**Place:** \_\_\_\_\_

**Date:** \_\_\_\_\_

## ANNEXURE – II

### BANK GUARANTEE FOR PERFORMANCE SECURITY

To,  
The Managing Director,  
**North Eastern Regional Agricultural Marketing Corporation Ltd. (NERAMAC)**  
NERAMAC Complex, Six Mile,  
Near Panjabari Flyover,  
Guwahati – 781022

Whereas \_\_\_\_\_ (name and address of the contractor) (hereinafter called “the Contractor”) has undertaken, in pursuance of Contract No. \_\_\_\_\_ dated \_\_\_\_\_, to execute works / services for:

**“Construction of Agarwood Cluster Processing Unit at Golaghat, Assam and Kadamtala, Tripura”**  
(hereinafter called “the Contract”).

And whereas you have stipulated in the said Contract that the Contractor shall furnish a Bank Guarantee by a Commercial Bank for the sum specified therein as security for compliance with its obligations as per the Contract;

And whereas we have agreed to give the Contractor such a Bank Guarantee:

#### **Now, therefore, we hereby declare:**

We are the guarantor and responsible to you, on behalf of the Contractor, up to a total amount of ₹ \_\_\_\_\_ (Rupees \_\_\_\_\_ only), and we undertake to pay you, upon your first written demand declaring the Contractor to be in default under the Contract and without cavil or argument, any sum or sums within the limits of the guarantee as aforesaid, without your needing to prove or show grounds or reasons for your demand.

We hereby waive the necessity of your demanding the said debt from the Contractor before presenting us with the demand.

We further agree that no change or addition to or other modification of the terms of the Contract or of any Contract documents shall in any way release us from any liability under this guarantee, and we hereby waive notice of any such change.

---

This guarantee shall be valid up to \_\_\_\_\_ (date).

Our branch at \_\_\_\_\_ (*Name & Address of Branch*) shall be liable to pay the guaranteed amount depending on the filing of a claim under this Bank Guarantee only if you serve upon us a written claim or demand on or before \_\_\_\_\_ (date), failing which the Bank shall be discharged of all liabilities under this guarantee.

**(Signature of Authorized Officer of the Bank)**

Name: \_\_\_\_\_

Designation: \_\_\_\_\_

Seal, Name & Address of Bank & Branch

*Note: Preferably at the headquarters of the authority competent to sanction the expenditure or at district/state headquarters.*

**ANNEXURE – III**

**CERTIFICATE OF CHARTERED ACCOUNTANT / STATUTORY AUDITOR**

**[On Auditor / Chartered Accountant’s Letterhead]**

Certified that the following is the turnover of M/s \_\_\_\_\_ as per returns filed with the Income Tax Department for the past three financial years.

**Name and Registered Address of Individual / Firm / Company:**

\_\_\_\_\_  
\_\_\_\_\_

**Financial Details**

Sl. No.	Description	2022–23	2023–24	2024–25
1	Annual Turnover			
2	Net Worth			
3	Total Revenues			

**Signature:** \_\_\_\_\_

**Name of Chartered Accountant:** \_\_\_\_\_

**Membership No. (ICAI):** \_\_\_\_\_

**UDIN:** \_\_\_\_\_

**Date:** \_\_\_\_\_

**Seal:** \_\_\_\_\_

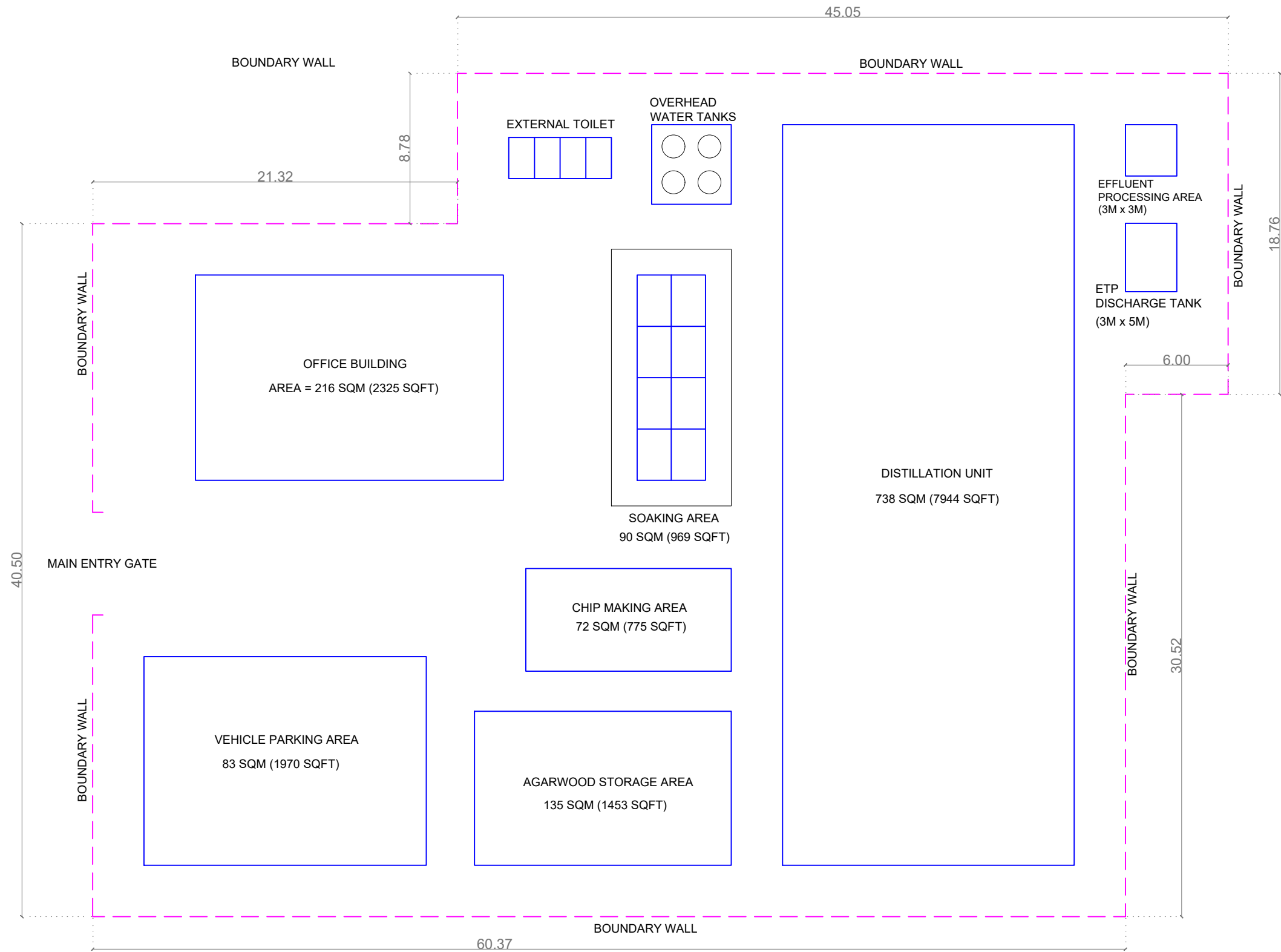

**AGARWOOD PROCESSING PLANT - SITE PLAN**  
PLOT AREA = 2605 SQM (28040 SQFT)

NOTE: ALL DIMENSIONS ARE IN METRES M UNLESS MARKED OTHERWISE.

PROJECT NAME:	AGARWOOD CLUSTER DEVELOPMENT PROJECT IN KADAMTALA TRIPURA AND IN GOLAGHAT ASSAM		
IMPLEMENTING AGENCY:	NORTH EASTERN REGIONAL AGRICULTURAL MARKETING CORPORATION		
DRAWING TITLE:	SITE PLAN		
	DRAWING NO.	REVISION	DATE
	NRMC/AGWD-1/01	REV-01	18-SEP-2025
REMARKS:			

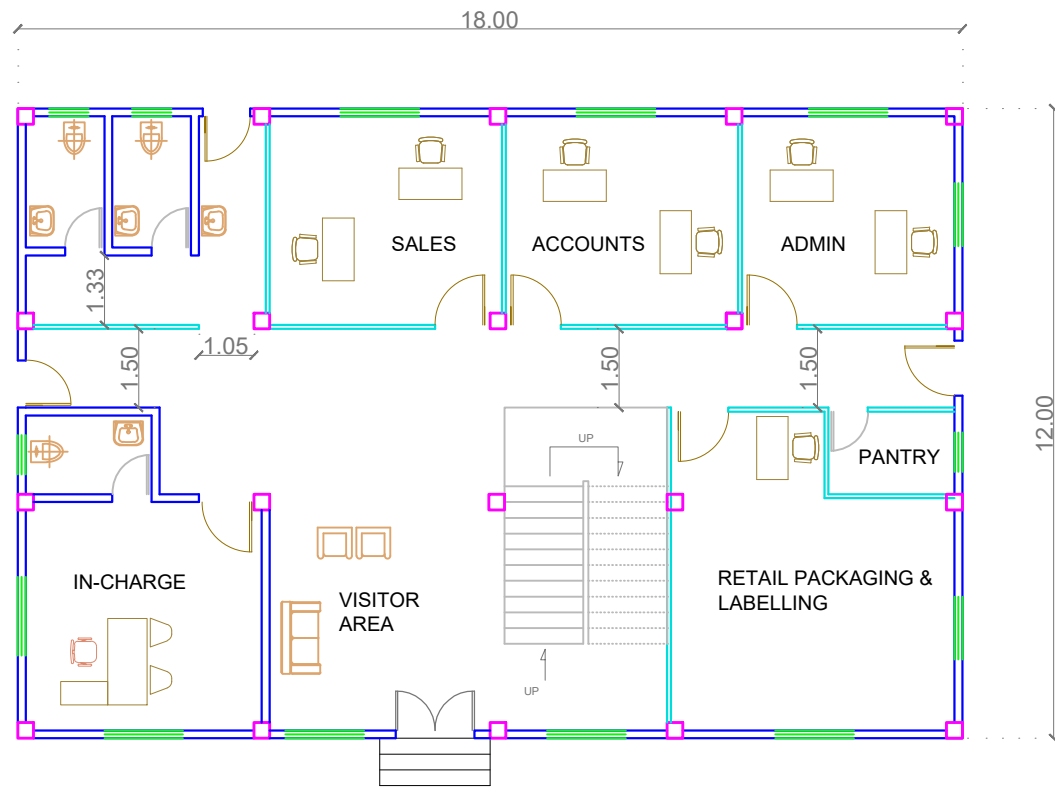

**GROUND FLOOR PLAN**  
(OFFICE BUILDING)

PLINTH AREA = 18.00 x 12.00 = 216 SQM (2325 SQFT)

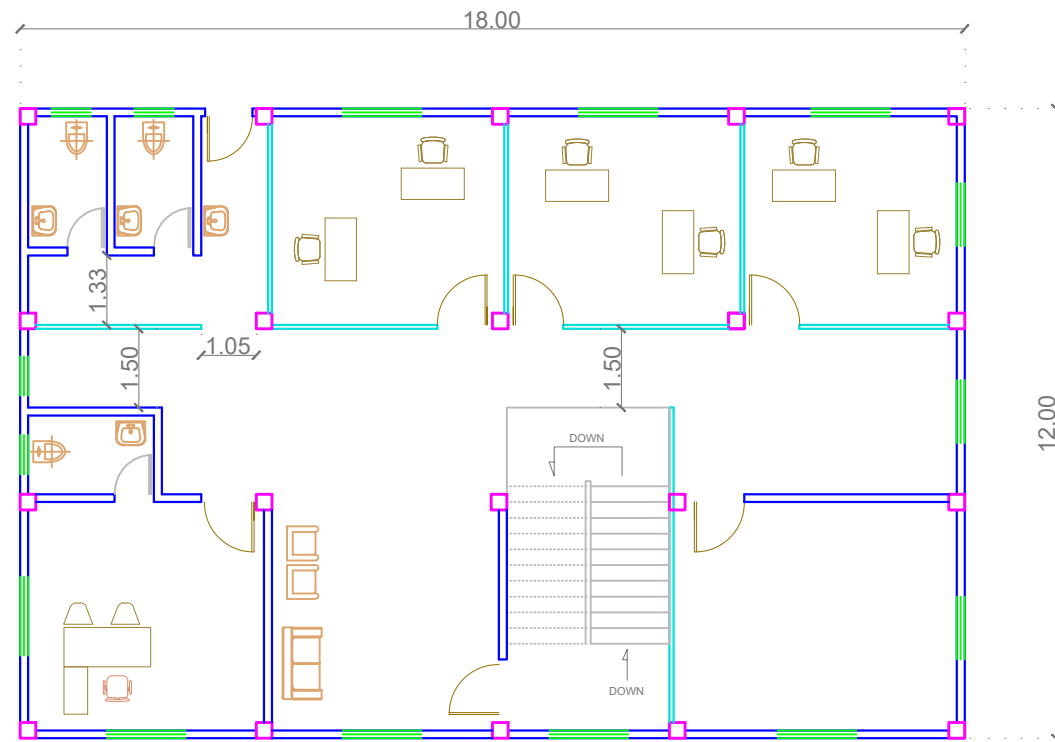

**FIRST FLOOR PLAN**  
(OFFICE BUILDING)

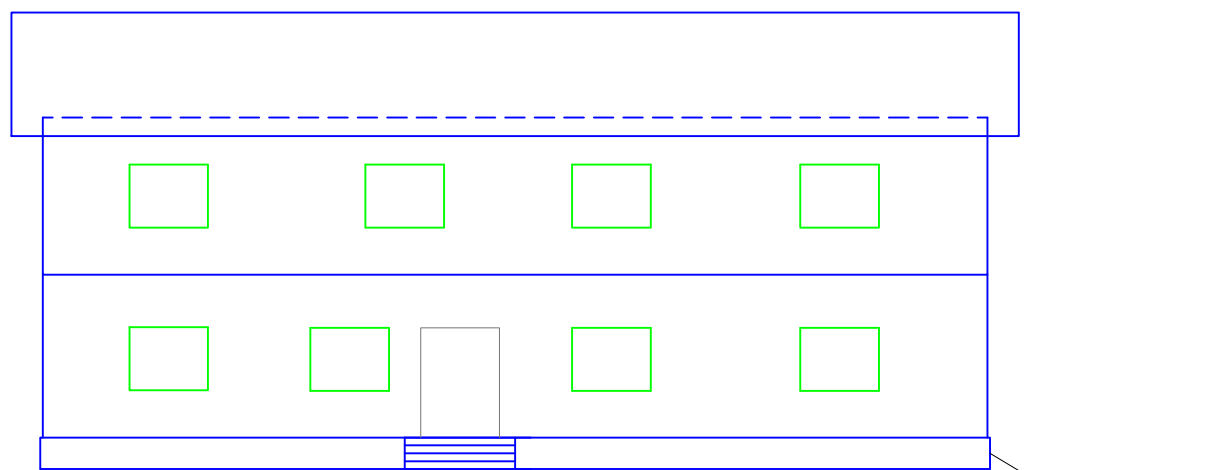

**OFFICE BUILDING - ELEVATION (FRONT)**

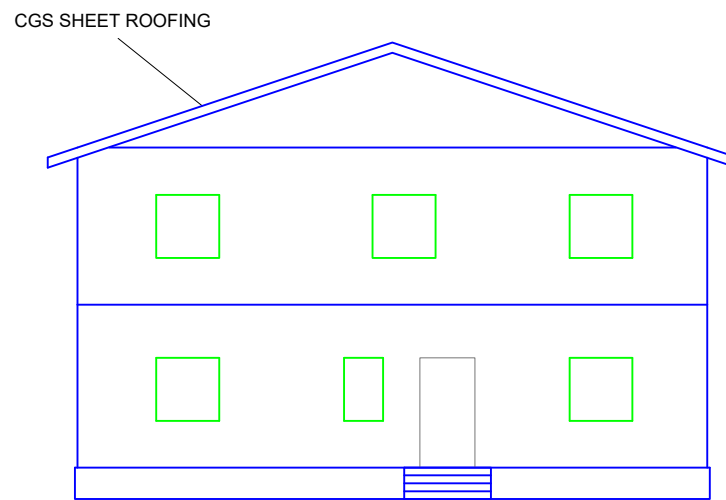

**OFFICE BUILDING - ELEVATION (SIDE)**

**NOTE:** ALL DIMENSIONS ARE IN METRES UNLESS MARKED OTHERWISE.

PROJECT NAME:	AGARWOOD CLUSTER DEVELOPMENT PROJECT IN KADAMTALA TRIPURA AND IN GOLAGHAT ASSAM	
IMPLEMENTING AGENCY:	NORTH EASTERN REGIONAL AGRICULTURAL MARKETING CORPORATION	
DRAWING TITLE:	PLAN AND ELEVATION OF OFFICE BUILDING	

DRAWING NO.	REVISION	DATE
NRMC/AGWD-1/02	REV-01	18-SEP-2025

REMARKS:

PROJECT NAME:	AGARWOOD CLUSTER DEVELOPMENT PROJECT IN KADAMTALA TRIPURA AND IN GOLAGHAT ASSAM		
IMPLEMENTING AGENCY:	NORTH EASTERN REGIONAL AGRICULTURAL MARKETING CORPORATION		
DRAWING TITLE:	STRUCTURAL DETAILS OF OFFICE BUILDING		
	DRAWING NO.	REVISION	DATE
	NRMC/AGWD-1/03	REV-01	18-SEP-2025
REMARKS:			

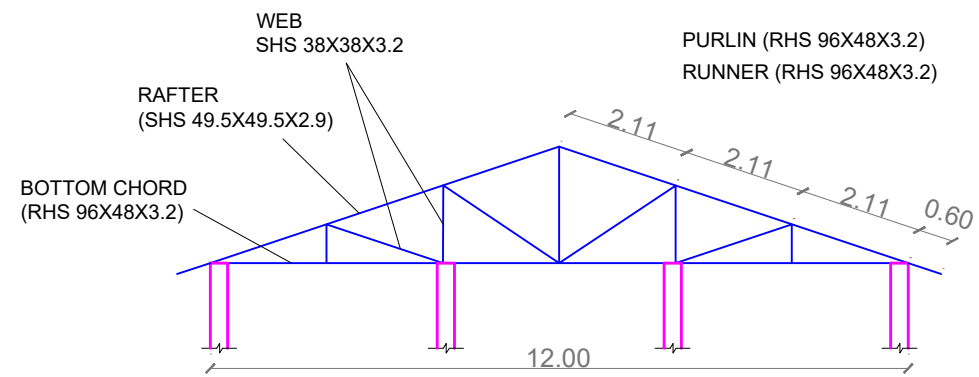

**OFFICE BUILDING**  
ROOF TRUSS DETAILS (TYPICAL BASED ON SPAN)

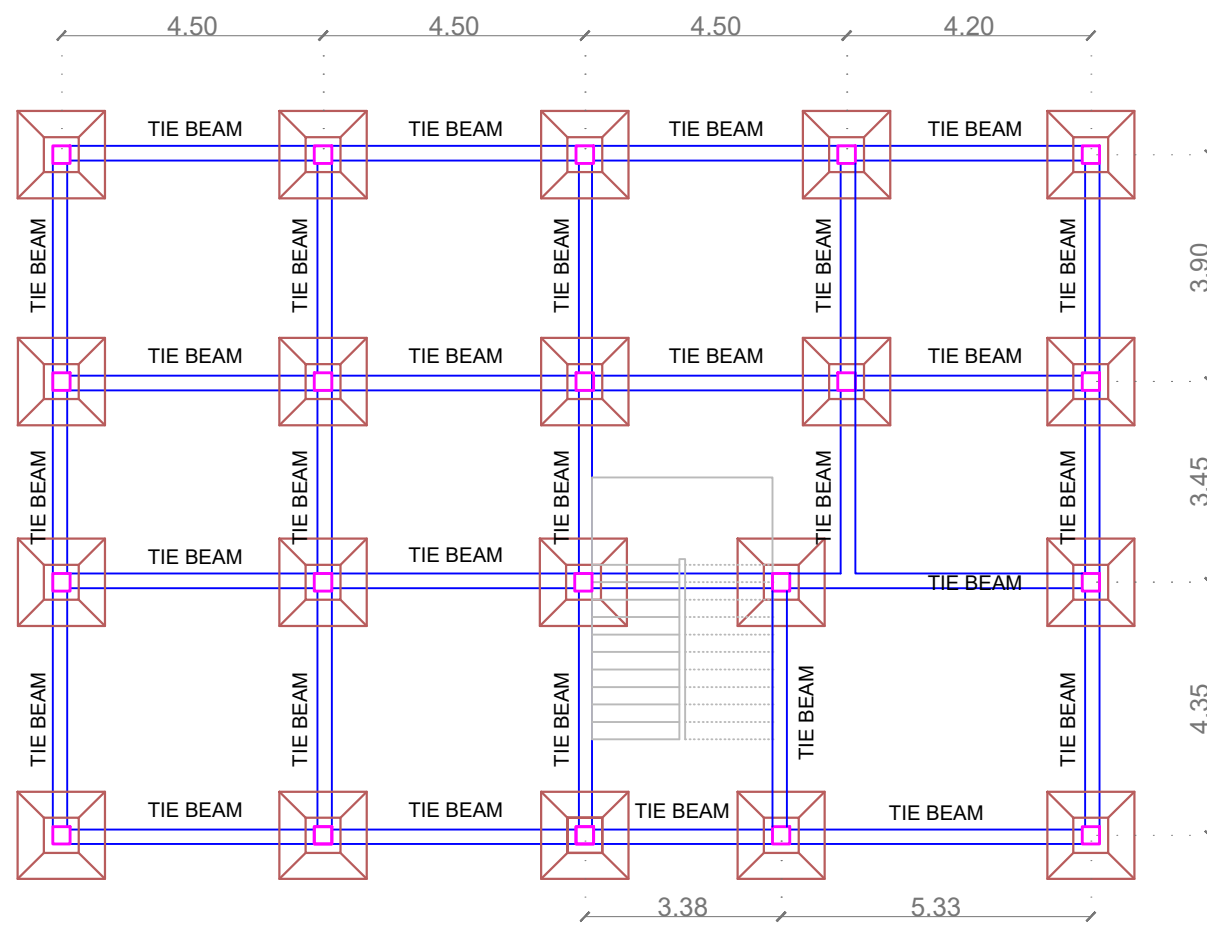

**OFFICE BUILDING**  
FOOTING AND COLUMN LAYOUT

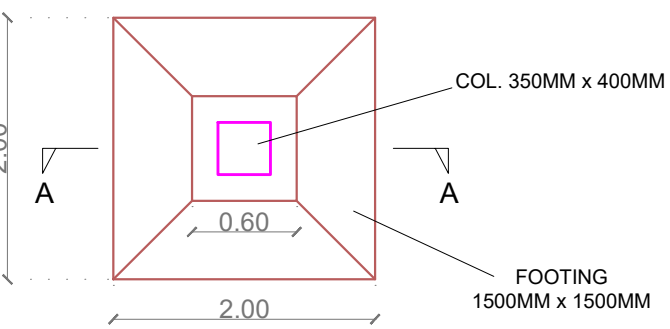
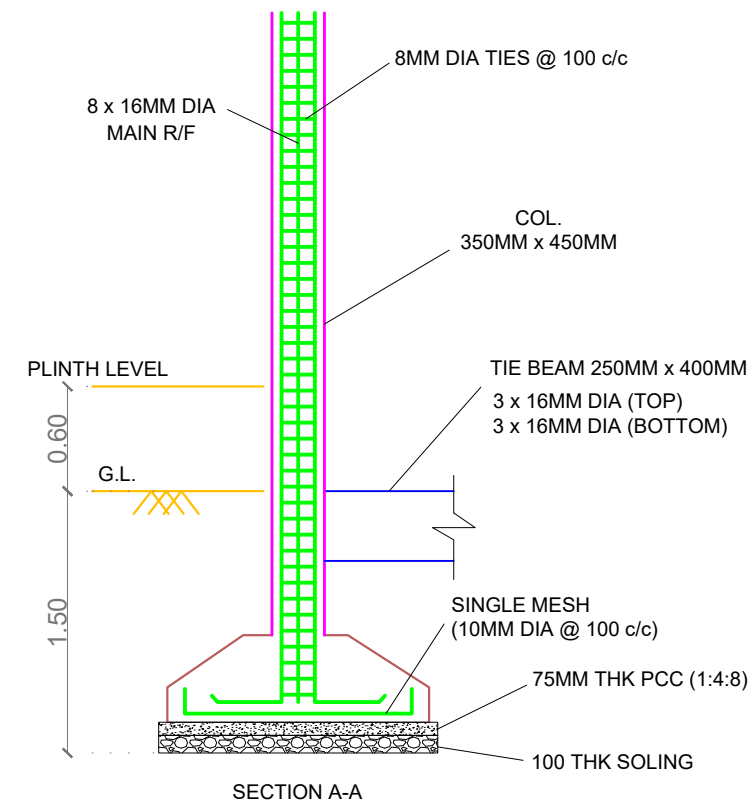

**FOOTING DETAILS (TYPICAL)**

**NOTE:** ALL DIMENSIONS ARE IN METRES M UNLESS MARKED OTHERWISE.

PROJECT NAME:	AGARWOOD CLUSTER DEVELOPMENT PROJECT IN KADAMTALA TRIPURA AND IN GOLAGHAT ASSAM	
IMPLEMENTING AGENCY:	NORTH EASTERN REGIONAL AGRICULTURAL MARKETING CORPORATION	
DRAWING TITLE:	PLAN & ELEVATION OF DISTILLATION UNIT	
	DRAWING NO.	REVISION
	NRMC/AGWD-1/04	REV-01
		DATE
		18-SEP-2025
REMARKS:		

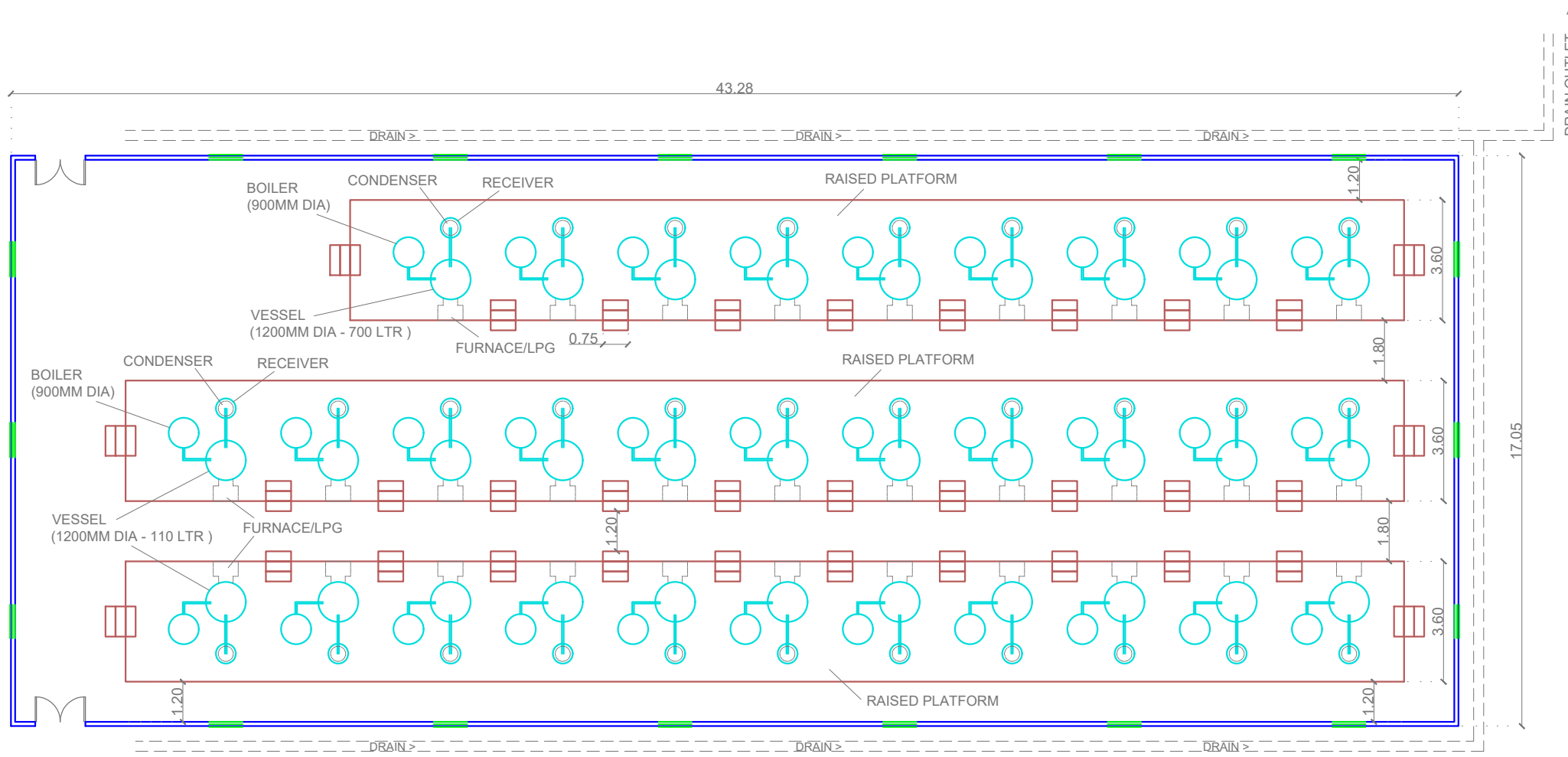

**DISTILLATION UNIT - PLAN**  
 SHED AREA = 43.28 x 17.05 = 738 SQM (7944 SQFT)

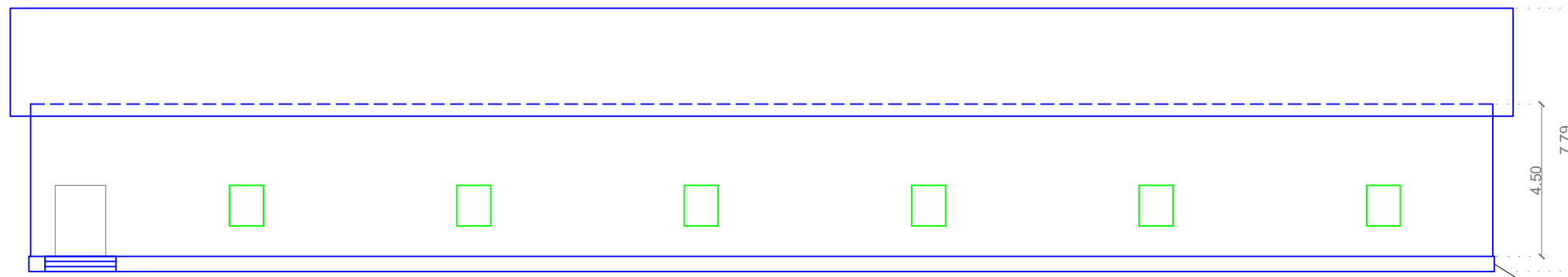

**DISTILLATION UNIT - ELEVATION (FRONT)**

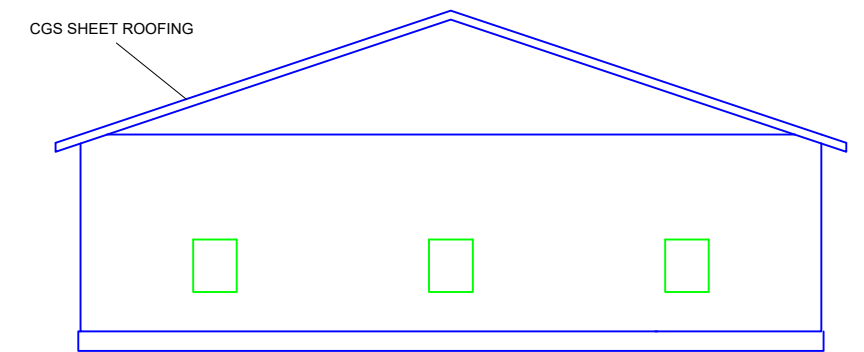

**DISTILLATION UNIT - ELEVATION (SIDE)**

**NOTE:** ALL DIMENSIONS ARE IN METRES UNLESS MARKED OTHERWISE.

PROJECT NAME:	AGARWOOD CLUSTER DEVELOPMENT PROJECT IN KADAMTALA TRIPURA AND IN GOLAGHAT ASSAM	
IMPLEMENTING AGENCY:	NORTH EASTERN REGIONAL AGRICULTURAL MARKETING CORPORATION	
DRAWING TITLE:	STRUCTURAL DETAILS OF DISTILLATION UNIT	
<u>DRAWING NO.</u>	<u>REVISION</u>	<u>DATE</u>
NRMC/AGWD-1/05	REV-01	18-SEP-2025
REMARKS:		

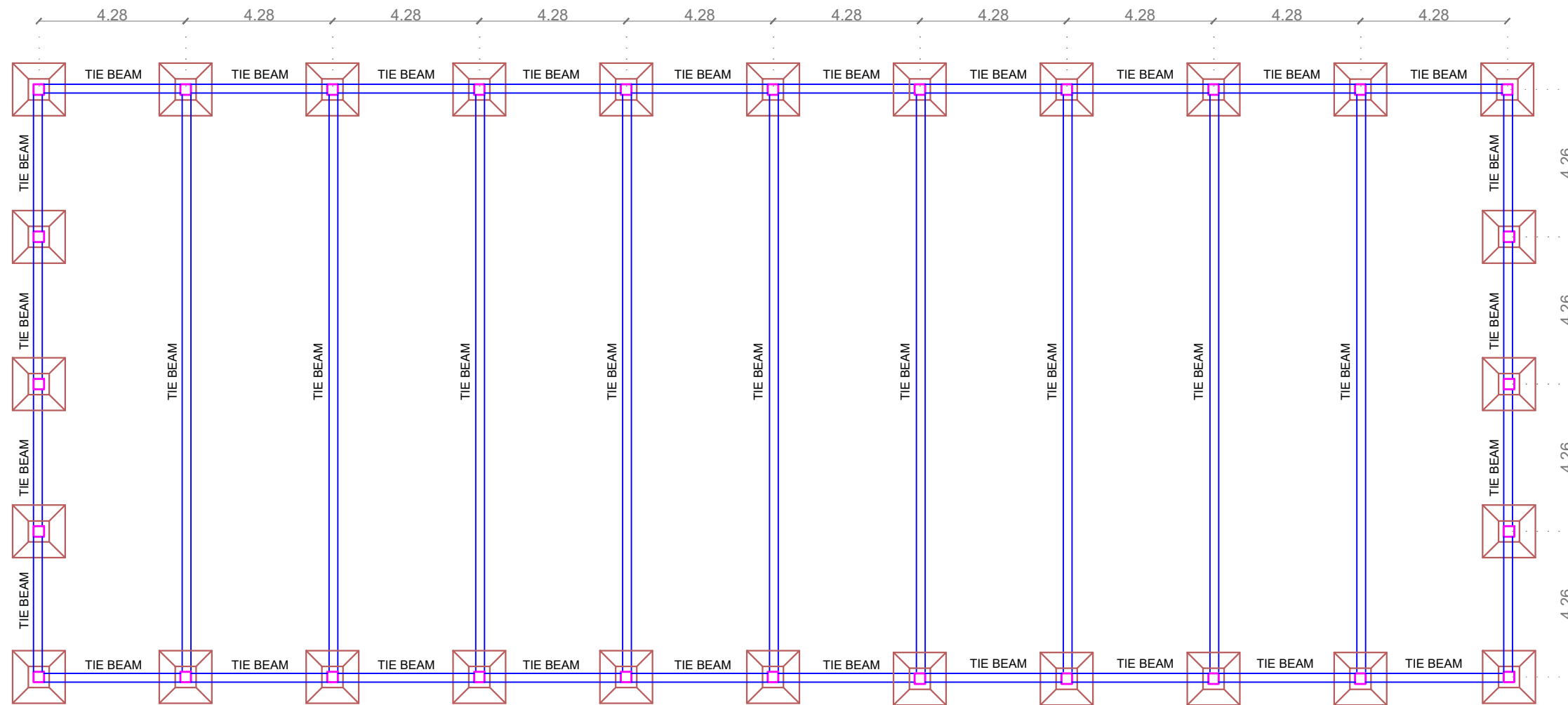

**DISTILLATION UNIT  
FOOTING AND COLUMN LAYOUT**

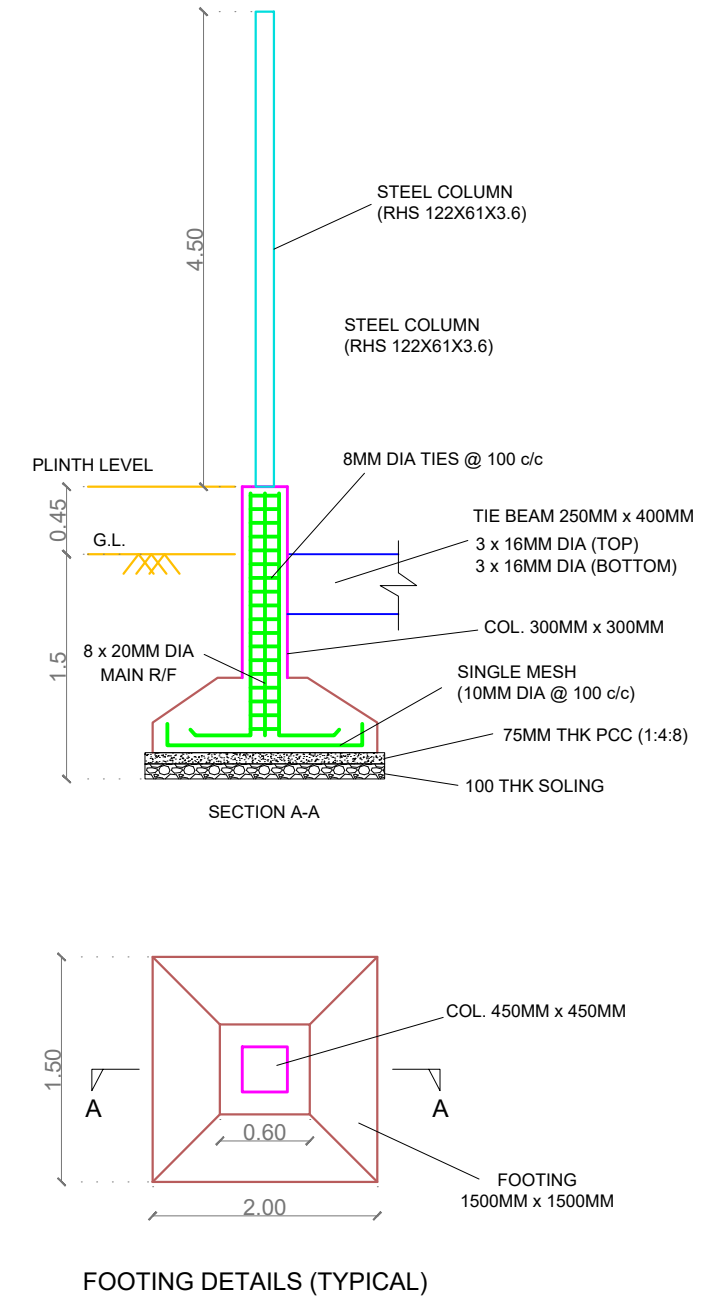

**NOTE: ALL DIMENSIONS ARE IN METRES UNLESS MARKED OTHERWISE.**

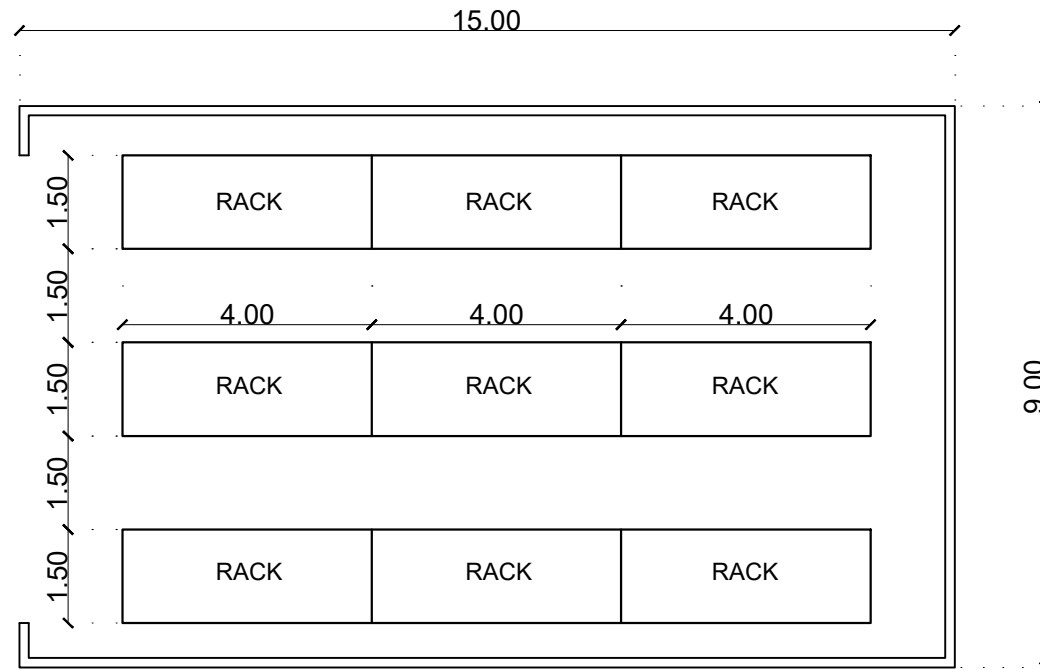

AGARWOOD STORAGE AREA  
AREA = 135 SQM (1453 SQFT)

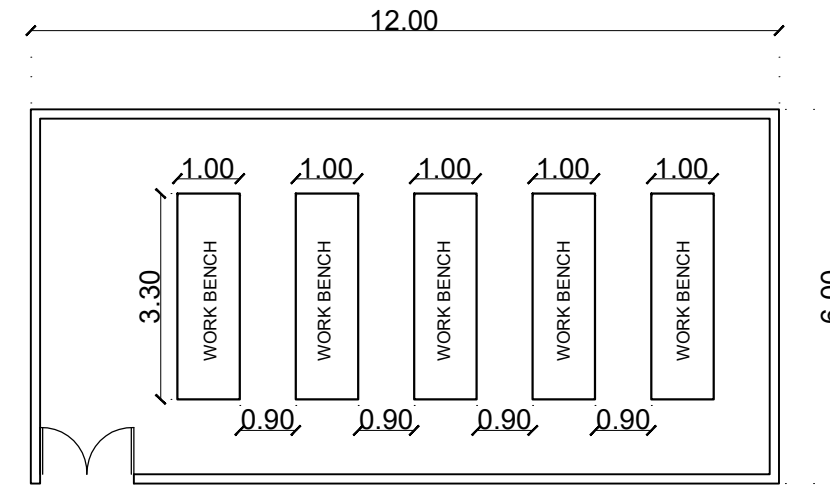

CHIP MAKING AREA  
AREA = 72 SQM (775 SQFT)

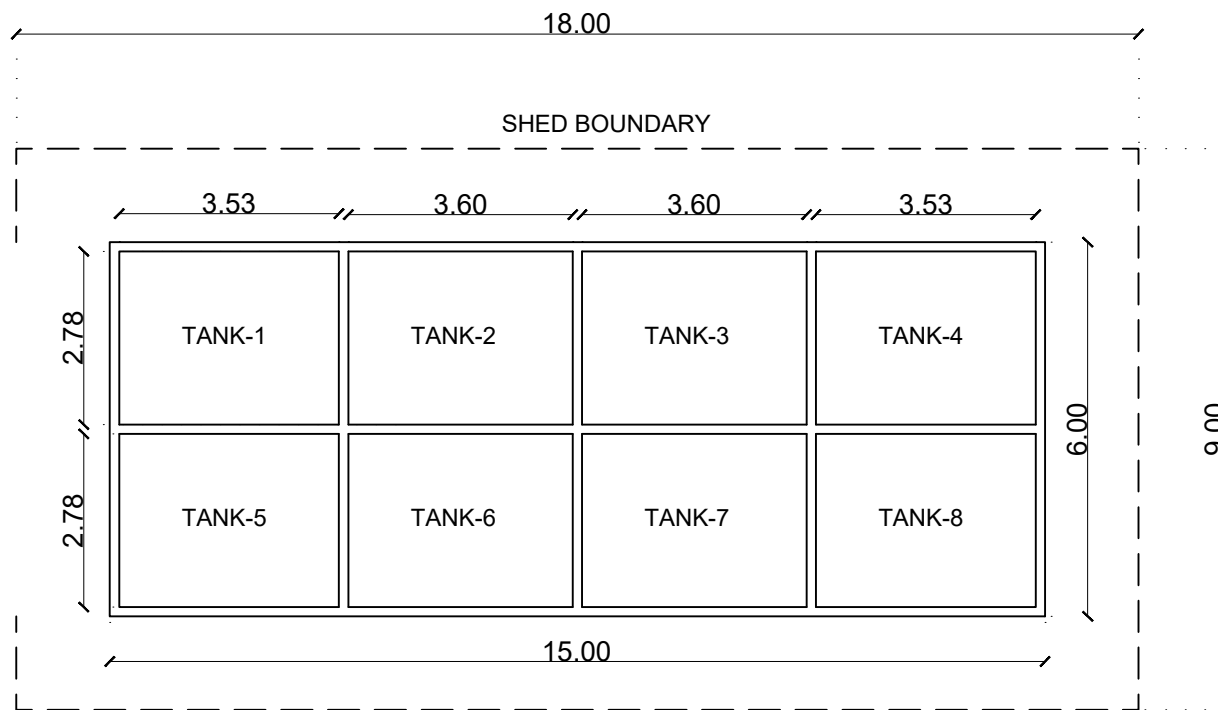

SOAKING AREA  
AREA = 90 SQM (969 SQFT)

NOTE: ALL DIMENSIONS ARE IN METRES M UNLESS MARKED OTHERWISE.

PROJECT NAME:	AGARWOOD CLUSTER DEVELOPMENT PROJECT IN KADAMTALA TRIPURA AND IN GOLAGHAT ASSAM	
IMPLEMENTING AGENCY:	NORTH EASTERN REGIONAL AGRICULTURAL MARKETING CORPORATION	
DRAWING TITLE:	STORAGE, CHIP MAKING & SOAKING AREA	
	<u>DRAWING NO.</u>	<u>REVISION</u>
	NRMC/AGWD-1/06	REV-00
		<u>DATE</u>
		20-JUN-2025
REMARKS:		

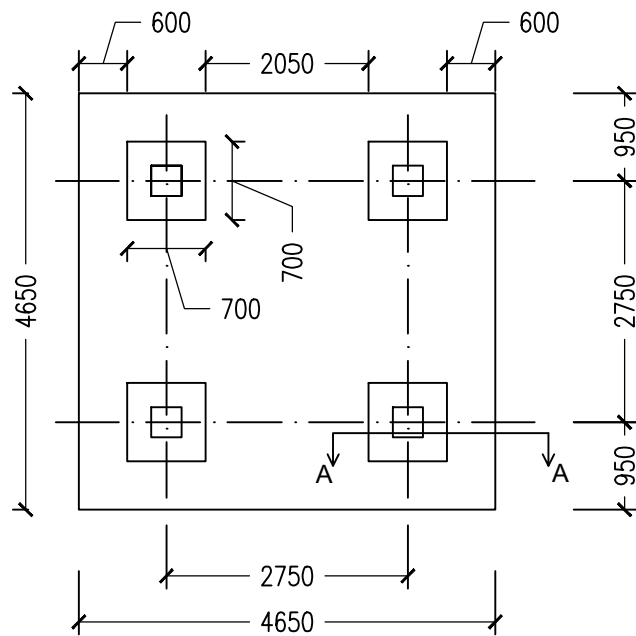
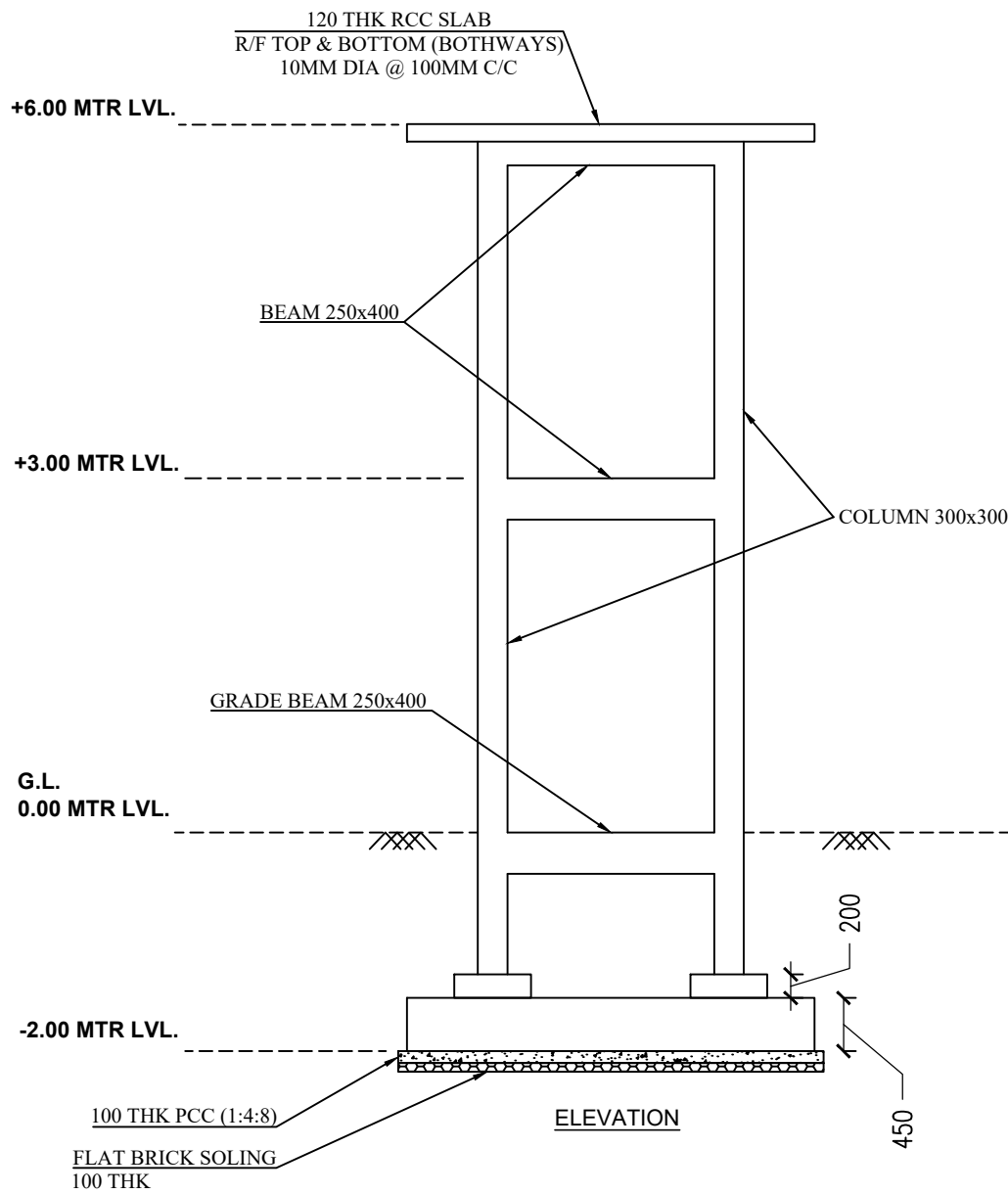
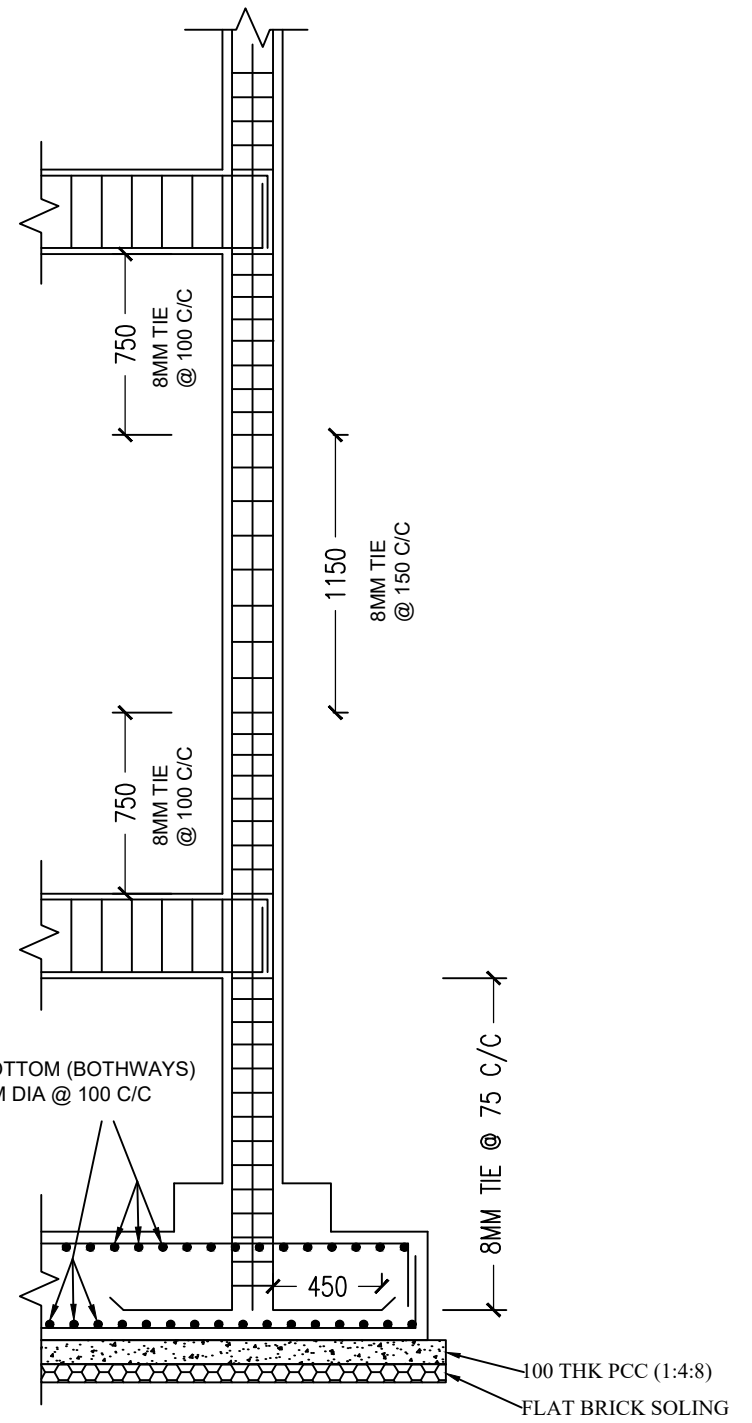
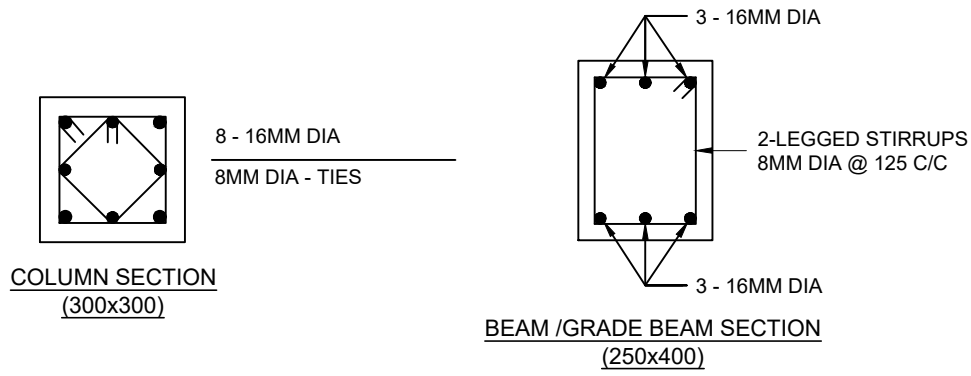

**NOTES:**

- ALL DIMENSIONS ARE IN MM UNLESS MARKED OTHERWISE.
- ALL R.C.C. WORK SHALL BE OF M20 GRADE.
- CLEAR COVER TO MAIN REINFORCEMENT SHALL BE AS FOLLOWS:
 

FOOTING	: 50 MM
BEAM	: 25 MM
SLAB	: 20 MM
COLUMN	: 40 MM
- ALL R.C.C. WORK SHALL BE OF M20 GRADE.
- ALL REINFORCEMENT SHALL BE OF HIGH STRENGTH DEFORMED STEEL BARS CONFORMING TO IS:1786-1985 (GRADE Fe-500) WITH 0.2%PROOF STRESS NOT LESS THAN 500 N/sqmm.
- LAP AND ANCHORAGE LENGTH ( $L_d$ ) OF BARS SHALL BE 47 TIMES OF BAR DIA. LAP SHALL BE STAGGERED AND AVOIDED AT THE POINT OF MAX. BENDING MOMENT.

**PROPOSAL DRAWING**

Project Name :

Agarwood Cluster Development Project  
in Kadamtala Tripura and in Golaghat Assam

Owner :

NORTH EASTERN AGRICULTURAL  
MARKETING CORPORATION, GUWAHATI

SIGN & SEAL

Drawing Title :

**RCC STRUCTURE TO SUPPORT  
PORTABLE OVERHEAD WATER TANKS  
(MAX CAPACITY 10,000 LTRS)**

Scale :

1:100

Drawing No.

Revision

Date

NRMC/AGWD-1/07

REV-00

20-JUN-2025

Remarks :

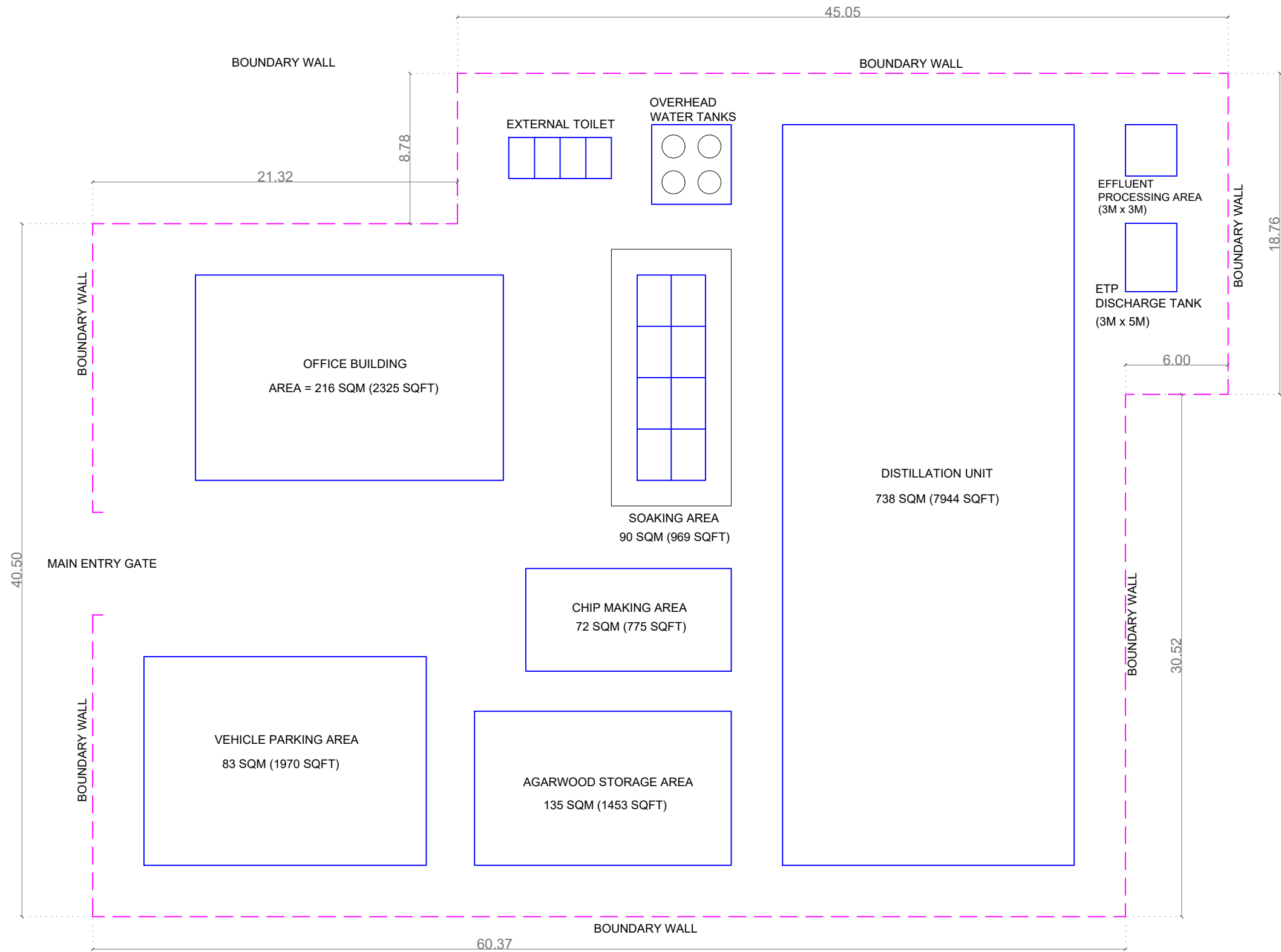

**AGARWOOD PROCESSING PLANT - SITE PLAN**  
PLOT AREA = 2605 SQM (28040 SQFT)

NOTE: ALL DIMENSIONS ARE IN METRES M UNLESS MARKED OTHERWISE.

PROJECT NAME:	AGARWOOD CLUSTER DEVELOPMENT PROJECT IN KADAMTALA TRIPURA AND IN GOLAGHAT ASSAM		
IMPLEMENTING AGENCY:	NORTH EASTERN REGIONAL AGRICULTURAL MARKETING CORPORATION		
DRAWING TITLE:	SITE PLAN		
	DRAWING NO.	REVISION	DATE
	NRMC/AGWD-1/01	REV-01	18-SEP-2025
REMARKS:			

PROJECT NAME:	AGARWOOD CLUSTER DEVELOPMENT PROJECT IN KADAMTALA TRIPURA AND IN GOLAGHAT ASSAM		
IMPLEMENTING AGENCY:	NORTH EASTERN REGIONAL AGRICULTURAL MARKETING CORPORATION		
DRAWING TITLE:	PLAN AND ELEVATION OF OFFICE BUILDING		
	DRAWING NO.	REVISION	DATE
	NRMC/AGWD-1/02	REV-00	20-JUN-2025
REMARKS:			

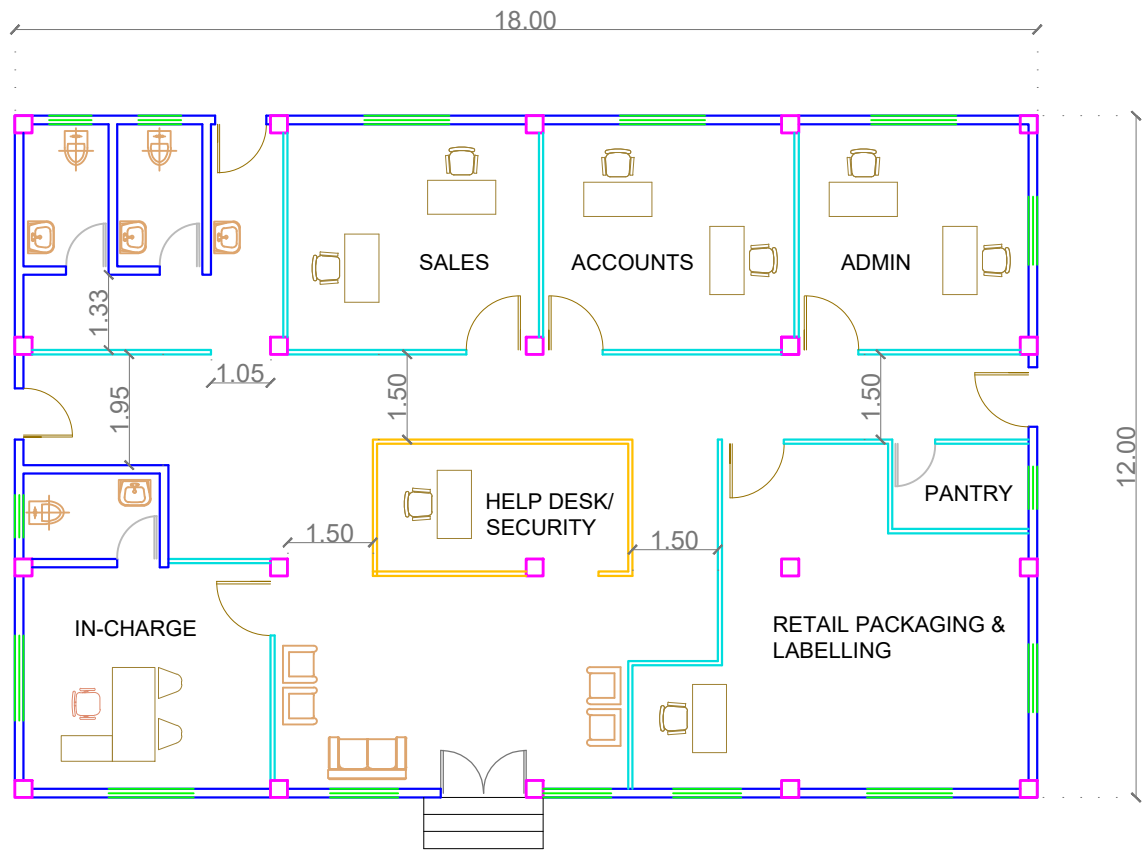

**OFFICE BUILDING - PLAN**

PLINTH AREA = 18.00 x 12.00 = 216 SQM (2325 SQFT)

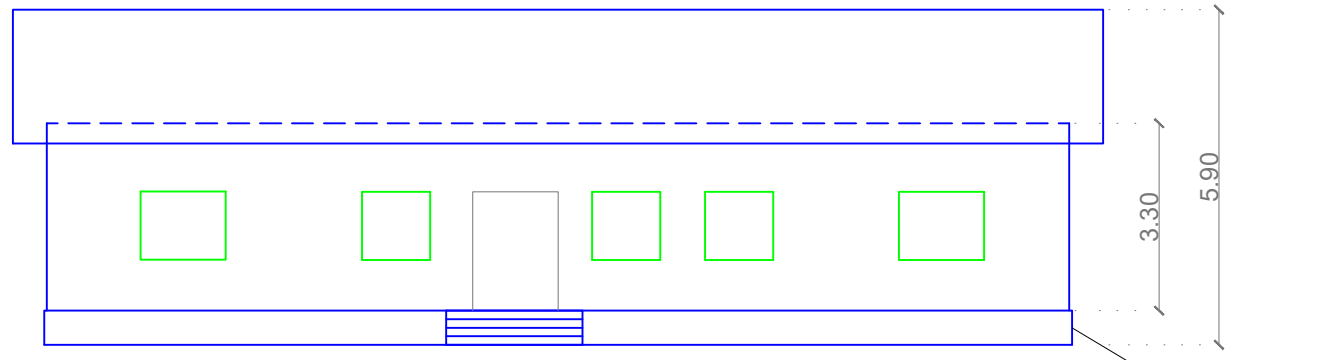

**OFFICE BUILDING - ELEVATION (FRONT)**

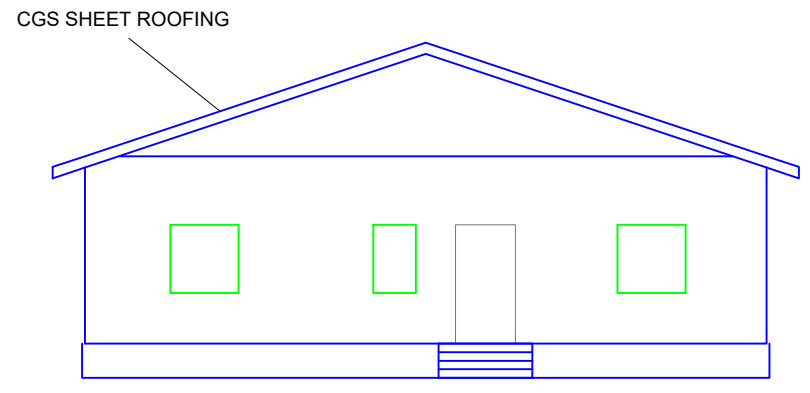

**OFFICE BUILDING - ELEVATION (SIDE)**

**NOTE: ALL DIMENSIONS ARE IN METRES M UNLESS MARKED OTHERWISE.**

PROJECT NAME:	AGARWOOD CLUSTER DEVELOPMENT PROJECT IN KADAMTALA TRIPURA AND IN GOLAGHAT ASSAM		
IMPLEMENTING AGENCY:	NORTH EASTERN REGIONAL AGRICULTURAL MARKETING CORPORATION		
DRAWING TITLE:	STRUCTURAL DETAILS OF OFFICE BUILDING		
	DRAWING NO.	REVISION	DATE
	NRMC/AGWD-1/03	REV-00	20-JUN-2025
REMARKS:			

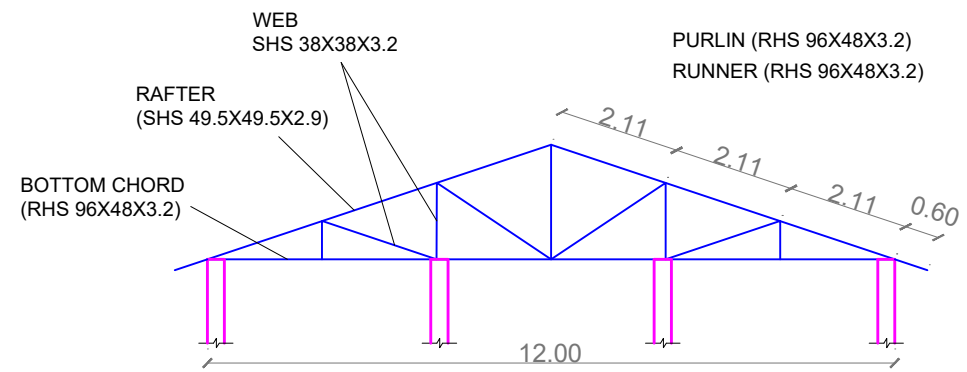

**OFFICE BUILDING**  
ROOF TRUSS DETAILS (TYPICAL BASED ON SPAN)

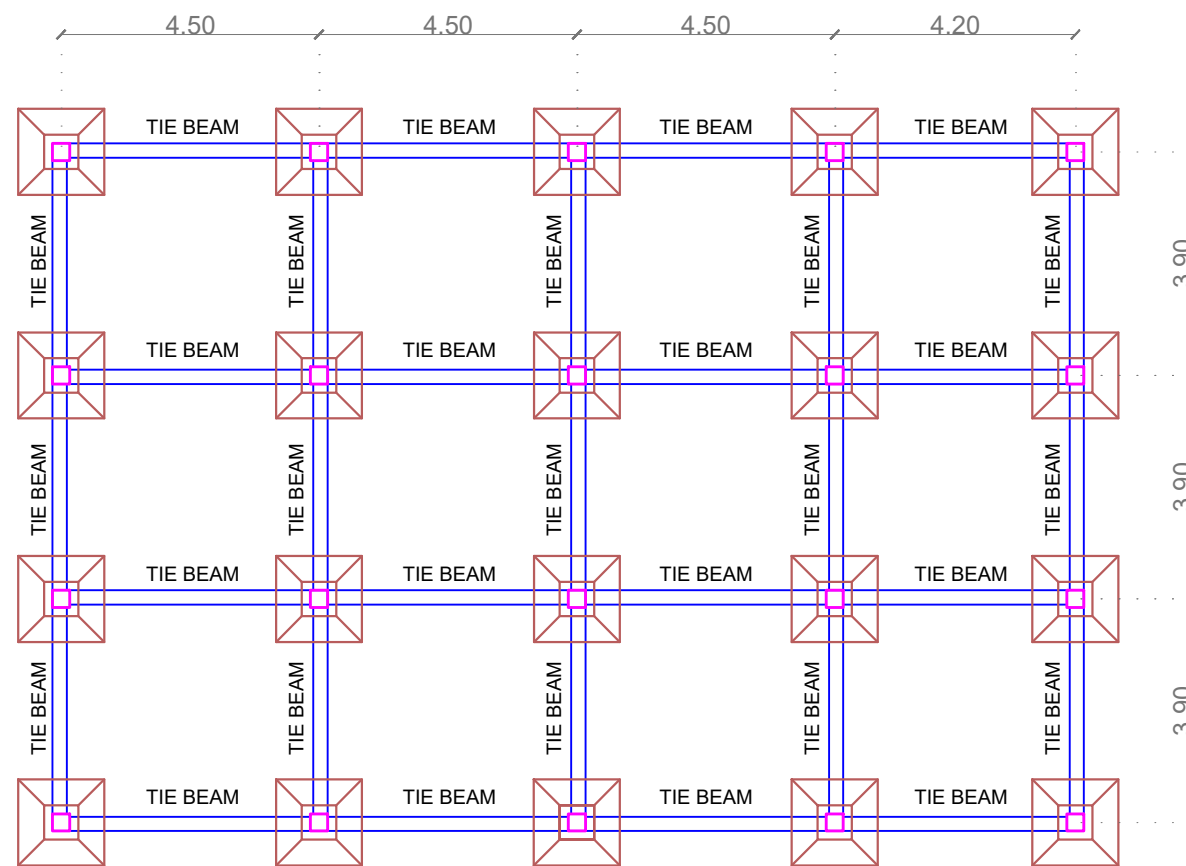

**OFFICE BUILDING**  
FOOTING AND COLUMN LAYOUT

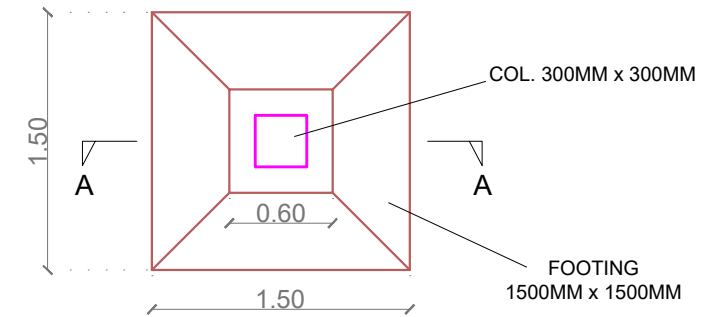
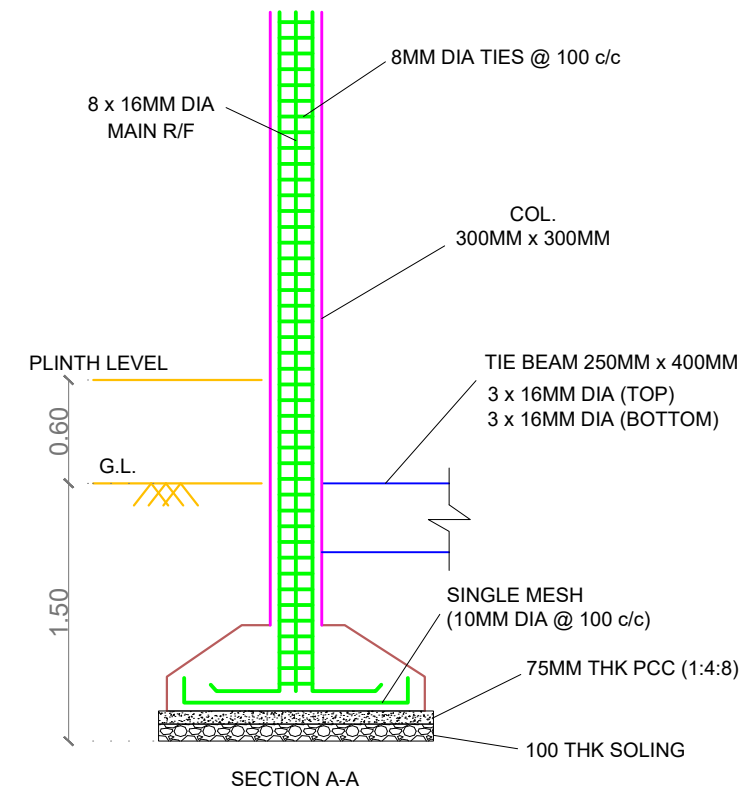

**FOOTING DETAILS (TYPICAL)**

**NOTE:** ALL DIMENSIONS ARE IN METRES M UNLESS MARKED OTHERWISE.



PROJECT NAME:	AGARWOOD CLUSTER DEVELOPMENT PROJECT IN KADAMTALA TRIPURA AND IN GOLAGHAT ASSAM	
IMPLEMENTING AGENCY:	NORTH EASTERN REGIONAL AGRICULTURAL MARKETING CORPORATION	
DRAWING TITLE:	STRUCTURAL DETAILS OF DISTILLATION UNIT	
<u>DRAWING NO.</u>	<u>REVISION</u>	<u>DATE</u>
NRMC/AGWD-1/05	REV-01	18-SEP-2025
REMARKS:		

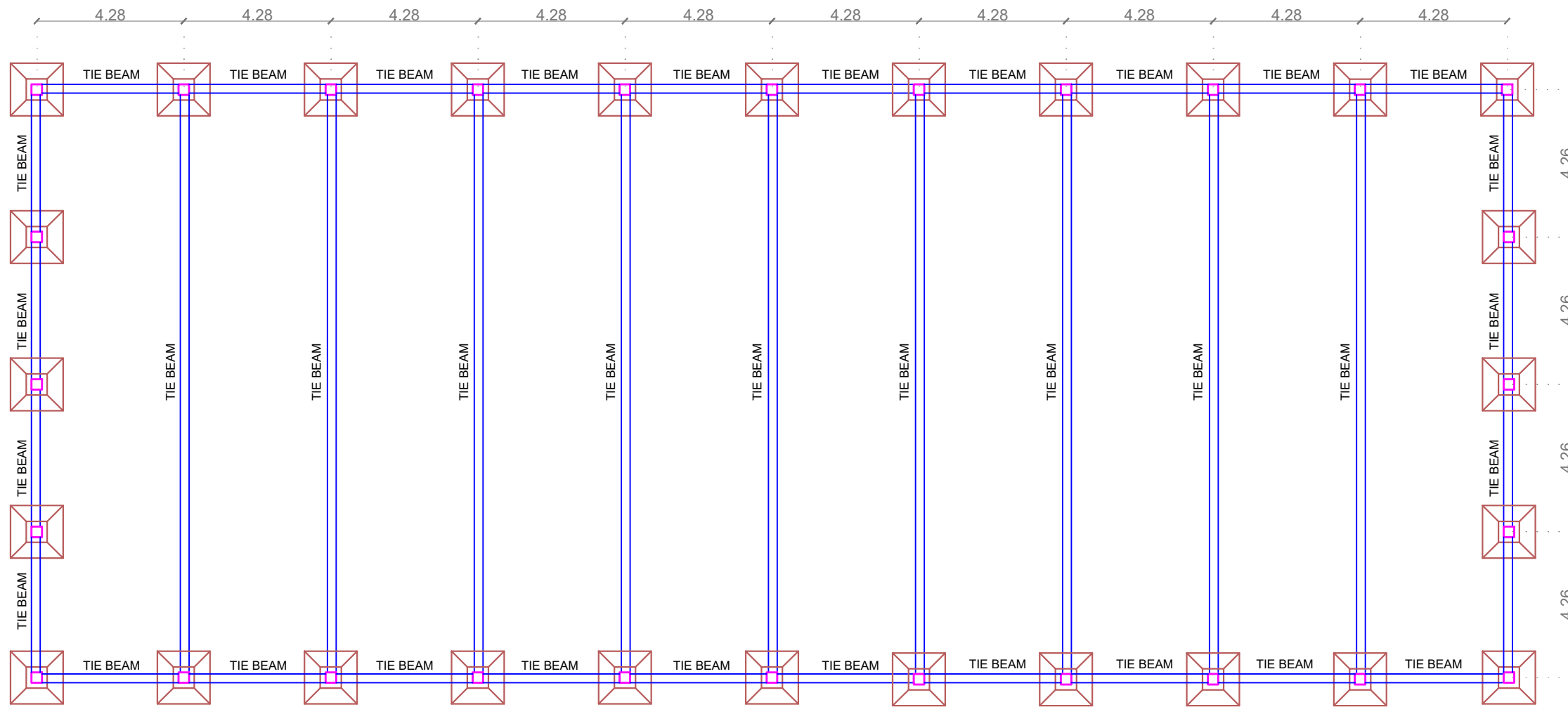

**DISTILLATION UNIT  
FOOTING AND COLUMN LAYOUT**

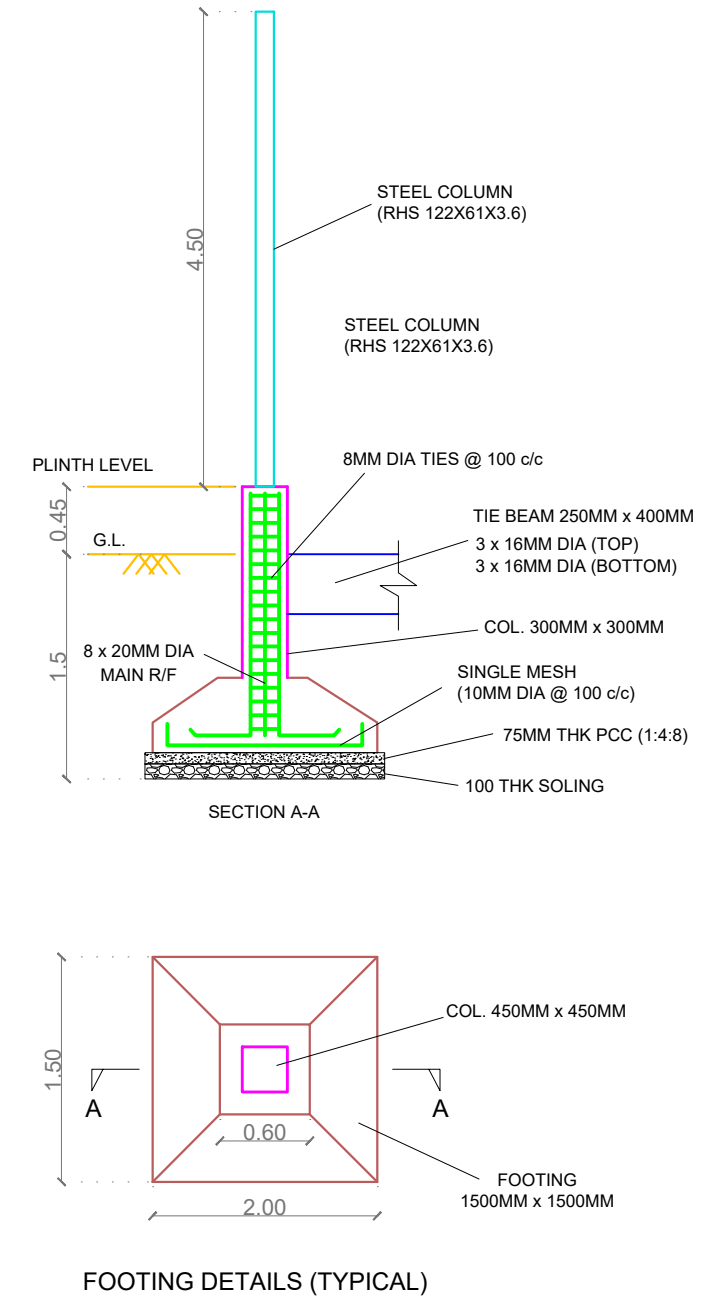

NOTE: ALL DIMENSIONS ARE IN METRES UNLESS MARKED OTHERWISE.

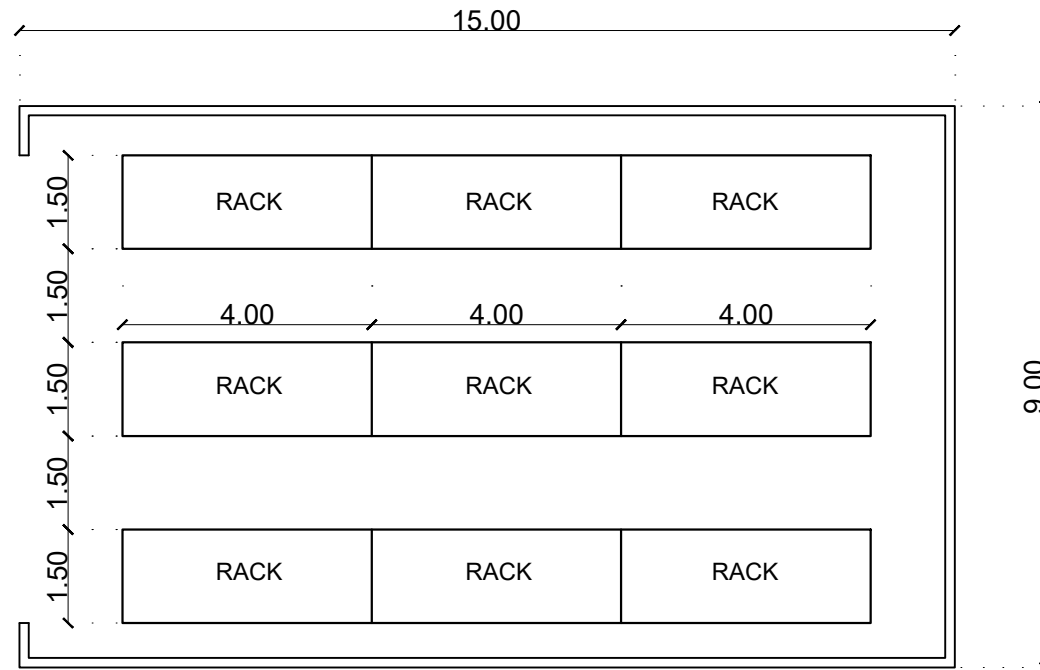

AGARWOOD STORAGE AREA  
 AREA = 135 SQM (1453 SQFT)

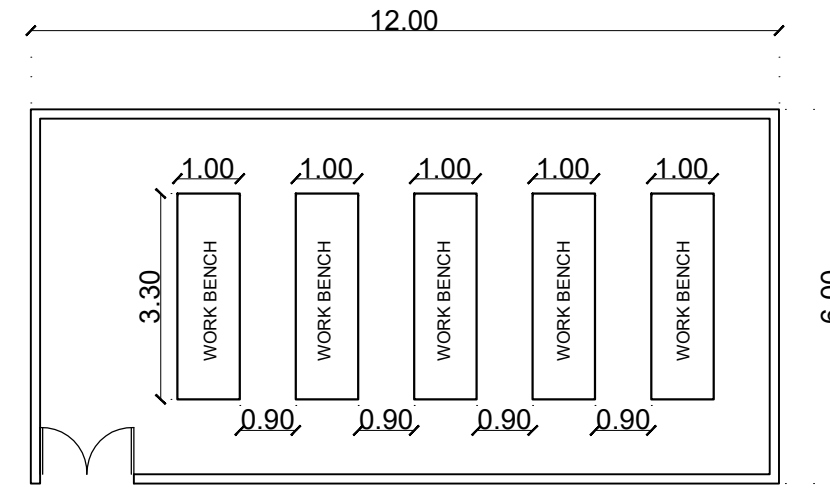

CHIP MAKING AREA  
 AREA = 72 SQM (775 SQFT)

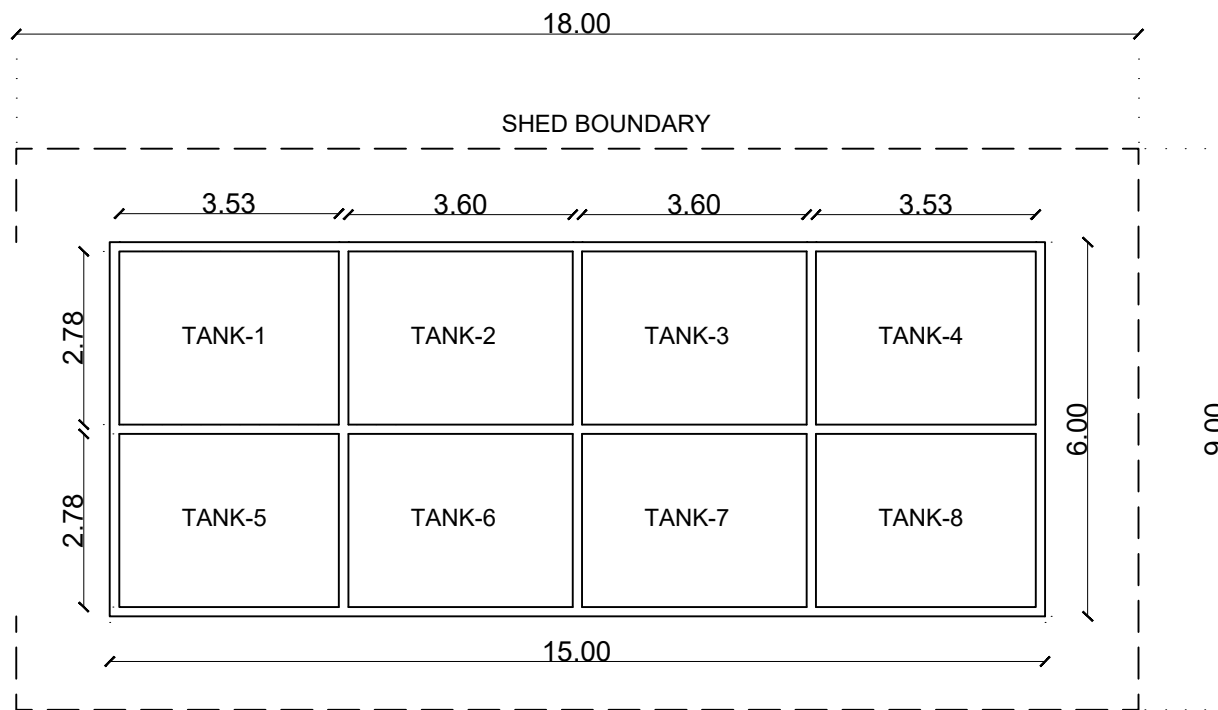

SOAKING AREA  
 AREA = 90 SQM (969 SQFT)

NOTE: ALL DIMENSIONS ARE IN METRES M UNLESS MARKED OTHERWISE.

PROJECT NAME:	AGARWOOD CLUSTER DEVELOPMENT PROJECT IN KADAMTALA TRIPURA AND IN GOLAGHAT ASSAM	
IMPLEMENTING AGENCY:	NORTH EASTERN REGIONAL AGRICULTURAL MARKETING CORPORATION	
DRAWING TITLE:	STORAGE, CHIP MAKING & SOAKING AREA	
	<u>DRAWING NO.</u>	<u>REVISION</u>
	NRMC/AGWD-1/06	REV-00
		<u>DATE</u>
		20-JUN-2025
REMARKS:		

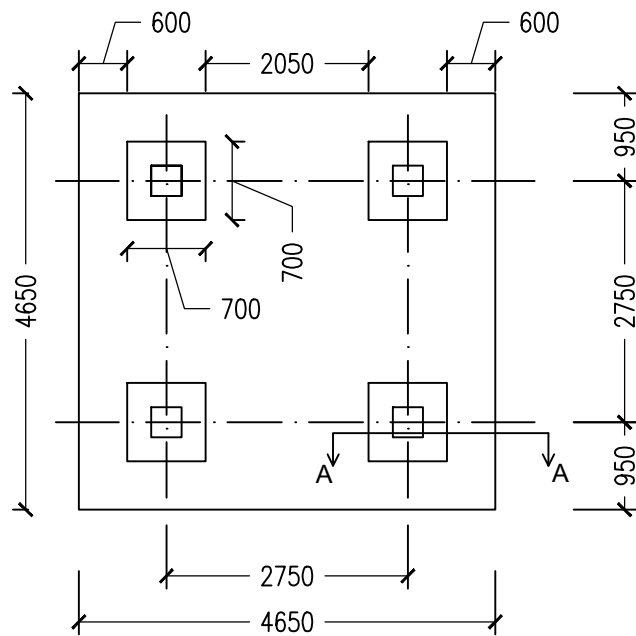
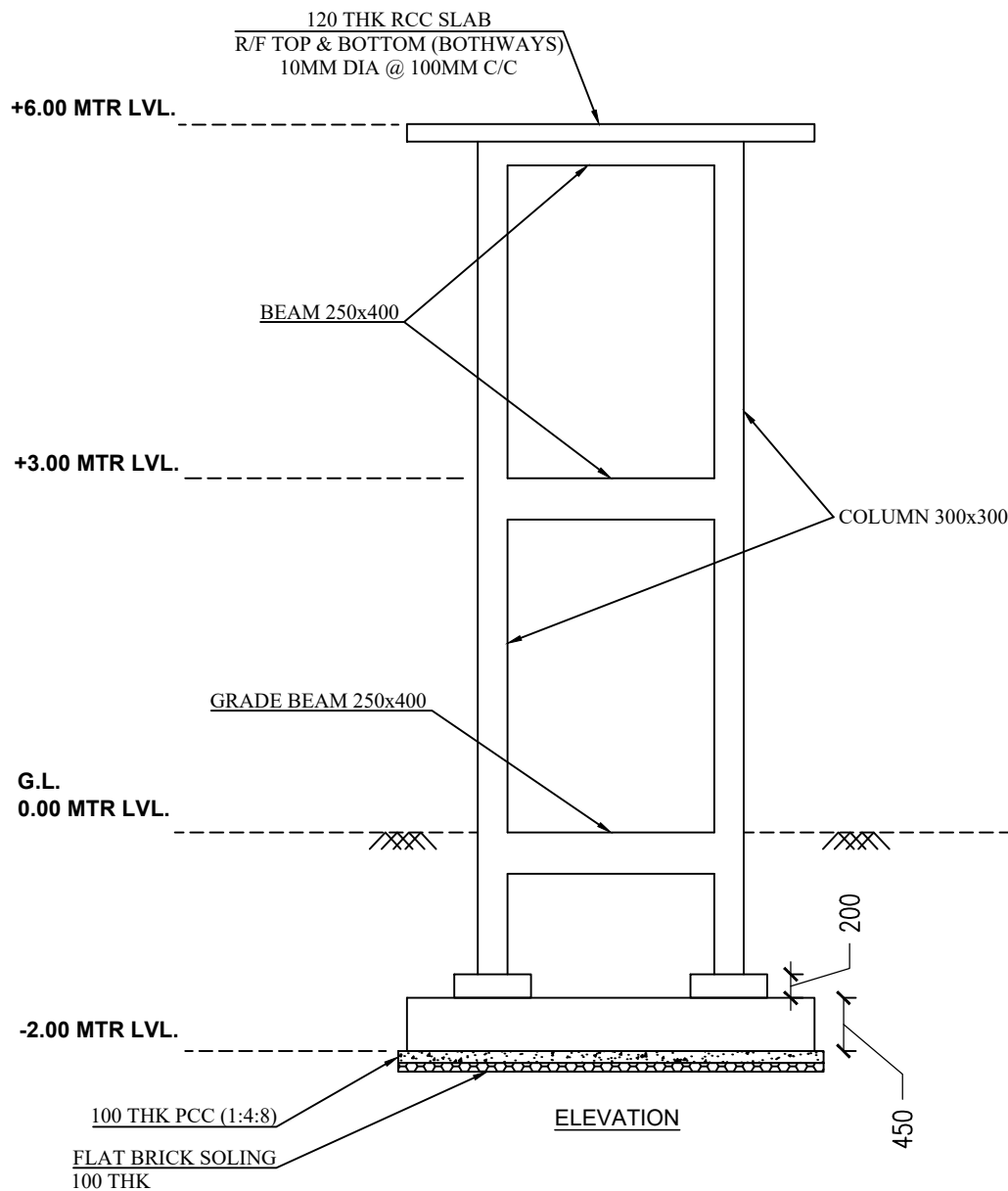
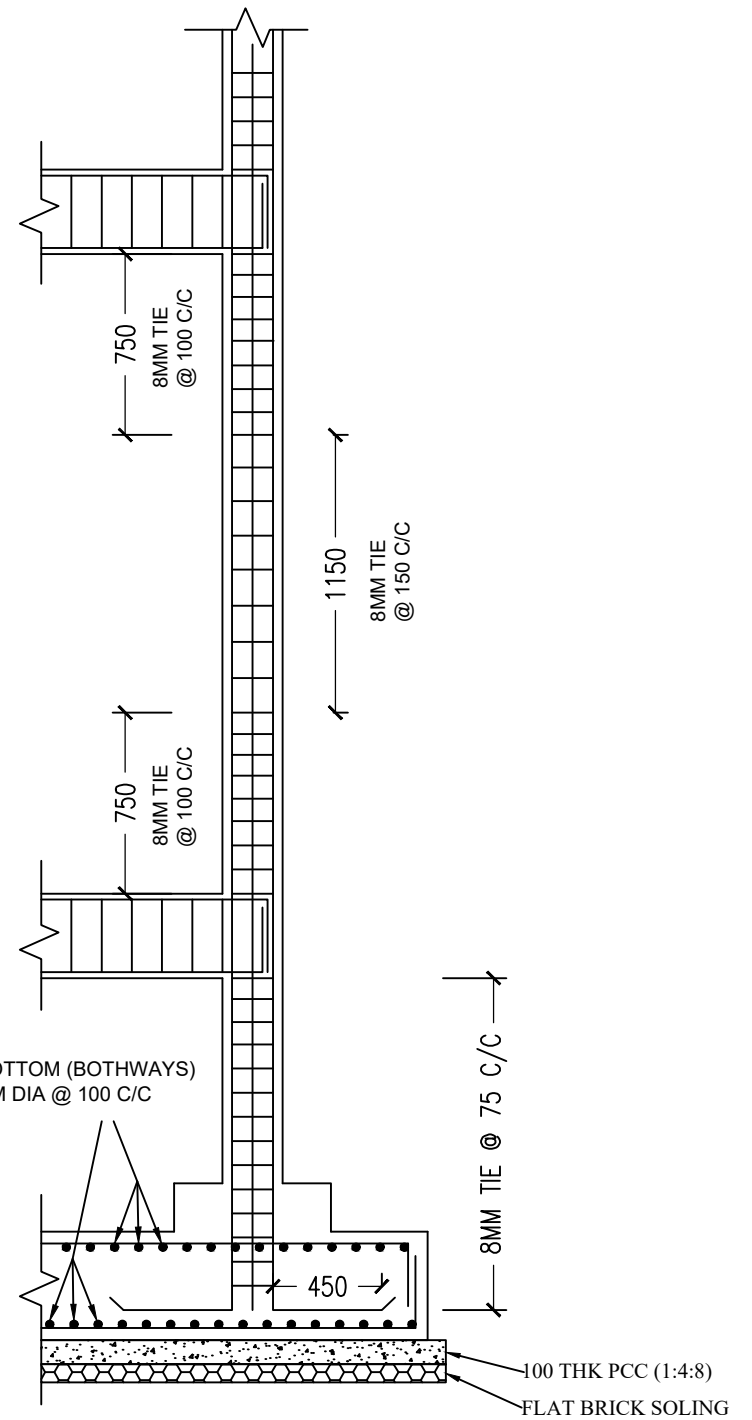
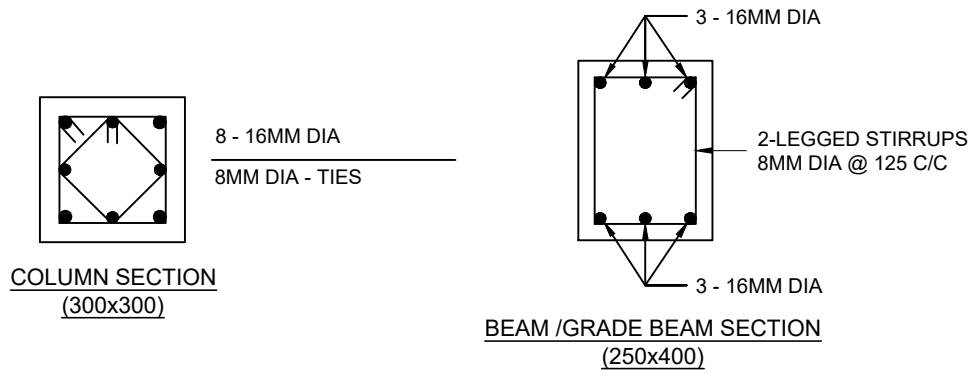

**NOTES:**

- ALL DIMENSIONS ARE IN MM UNLESS MARKED OTHERWISE.
- ALL R.C.C. WORK SHALL BE OF M20 GRADE.
- CLEAR COVER TO MAIN REINFORCEMENT SHALL BE AS FOLLOWS:
 

FOOTING	: 50 MM
BEAM	: 25 MM
SLAB	: 20 MM
COLUMN	: 40 MM
- ALL R.C.C. WORK SHALL BE OF M20 GRADE.
- ALL REINFORCEMENT SHALL BE OF HIGH STRENGTH DEFORMED STEEL BARS CONFORMING TO IS:1786-1985 (GRADE Fe-500) WITH 0.2%PROOF STRESS NOT LESS THAN 500 N/sqmm.
- LAP AND ANCHORAGE LENGTH ( $L_d$ ) OF BARS SHALL BE 47 TIMES OF BAR DIA. LAP SHALL BE STAGGERED AND AVOIDED AT THE POINT OF MAX. BENDING MOMENT.

PROPOSAL DRAWING		
Project Name :		
Agarwood Cluster Development Project in Kadamtala Tripura and in Golaghat Assam		
Owner :	SIGN & SEAL	
NORTH EASTERN AGRICULTURAL MARKETING CORPORATION, GUWAHATI		
Drawing Title :	Scale :	
<b>RCC STRUCTURE TO SUPPORT PORTABLE OVERHEAD WATER TANKS (MAX CAPACITY 10,000 LTRS)</b>		
1:100		
Drawing No.	Revision	Date
NRMC/AGWD-1/07	REV-00	20-JUN-2025
Remarks :		